

Searching for the Particles of the Early Universe

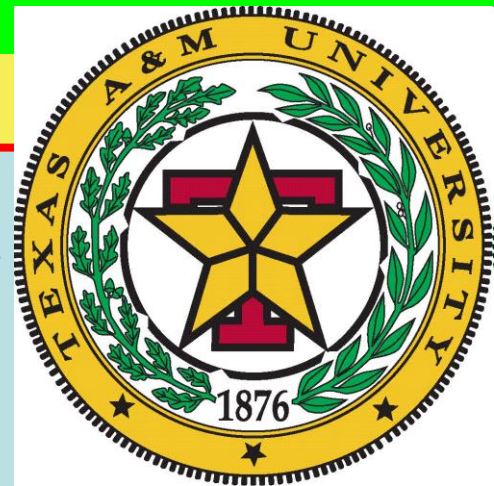

David Toback
Texas A&M
University



Outline

- Dark Matter in Astronomy, Cosmology and Particle Physics
- Supersymmetry and How it Could Help
- Searching for New Particles in Collider Physics Experiments
 - Recreating and Studying the Conditions of the Early Universe
- Looking towards the Future with the LHC

Dark Matter in Astronomy and Cosmology

Galaxy Rotation Data

Cosmic Microwave Background Data from WMAP

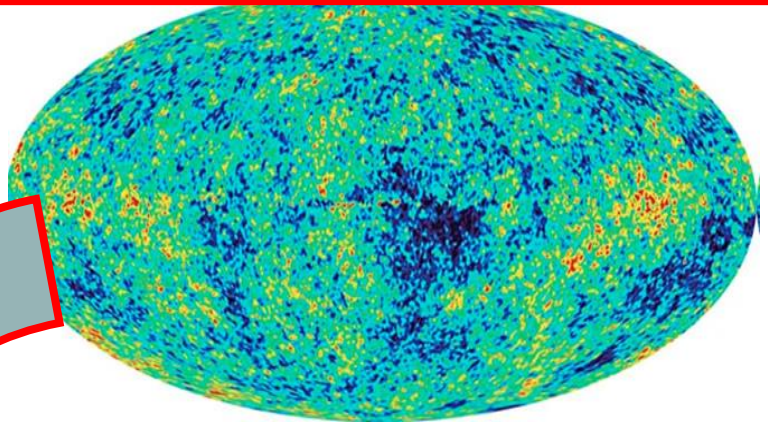
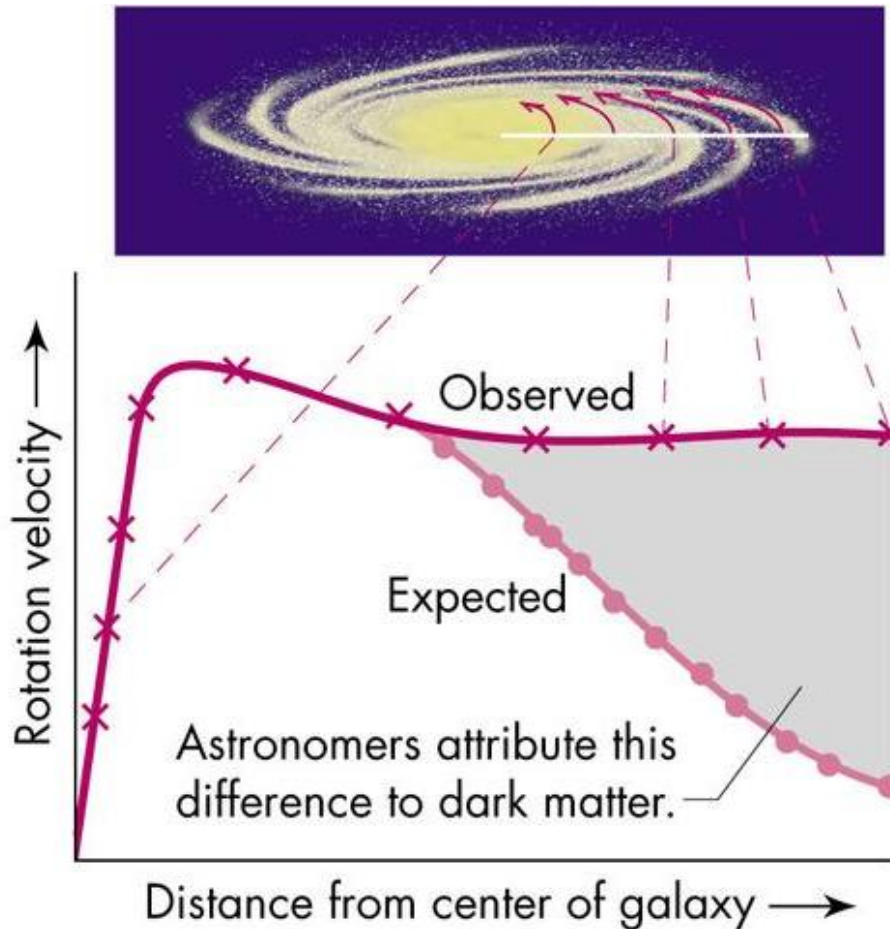

Evidence for Dark Matter as Particles

Colliding Galaxy Cluster

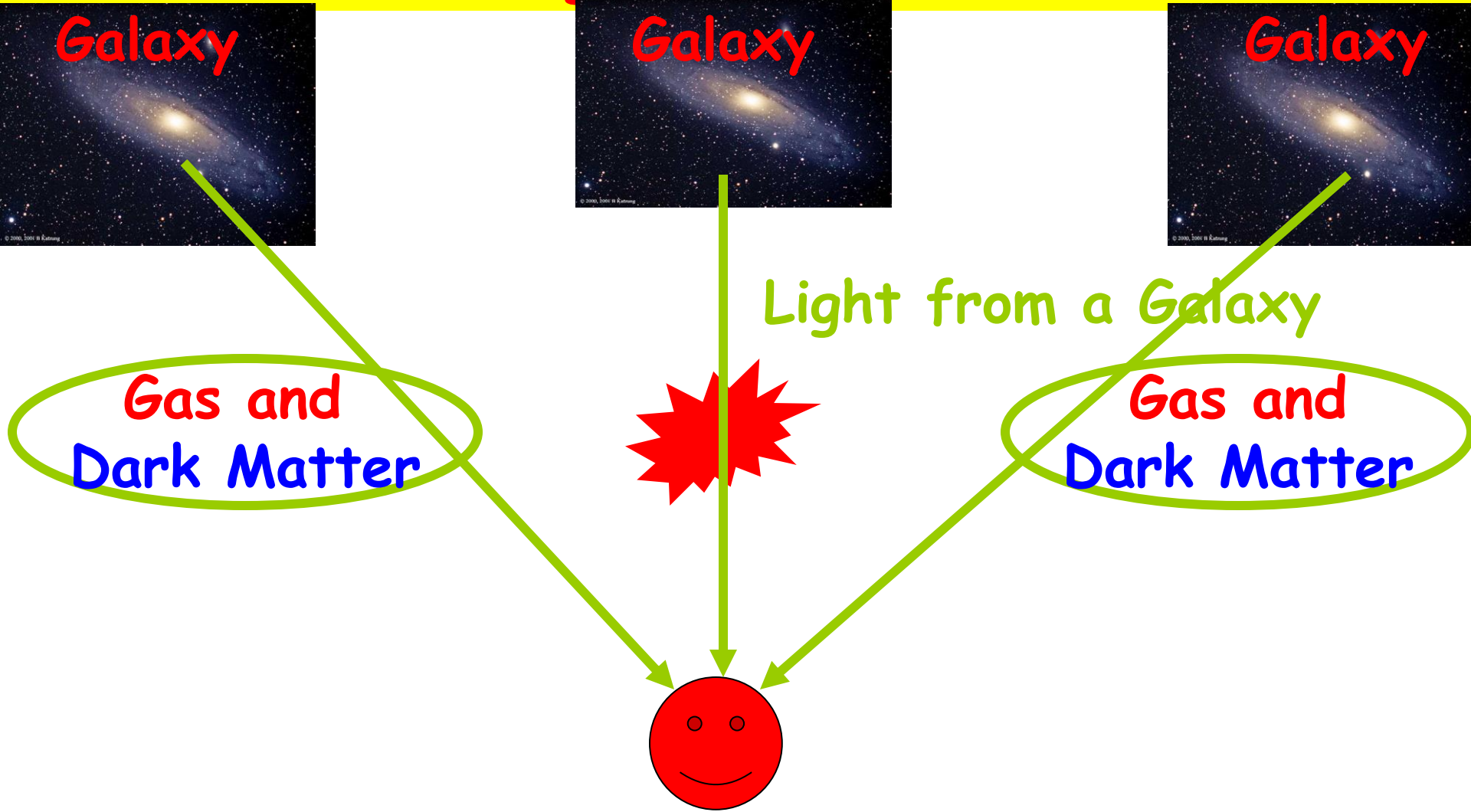

Blue (Dark Matter) is the mass as measured by gravitational lensing:
Pass through \rightarrow Weakly

Red part from x-ray observations
Slowed \rightarrow Particles with Standard Model

Simulation without Dark Matter

*Simulation with Dark Matter
Consistent with Data*

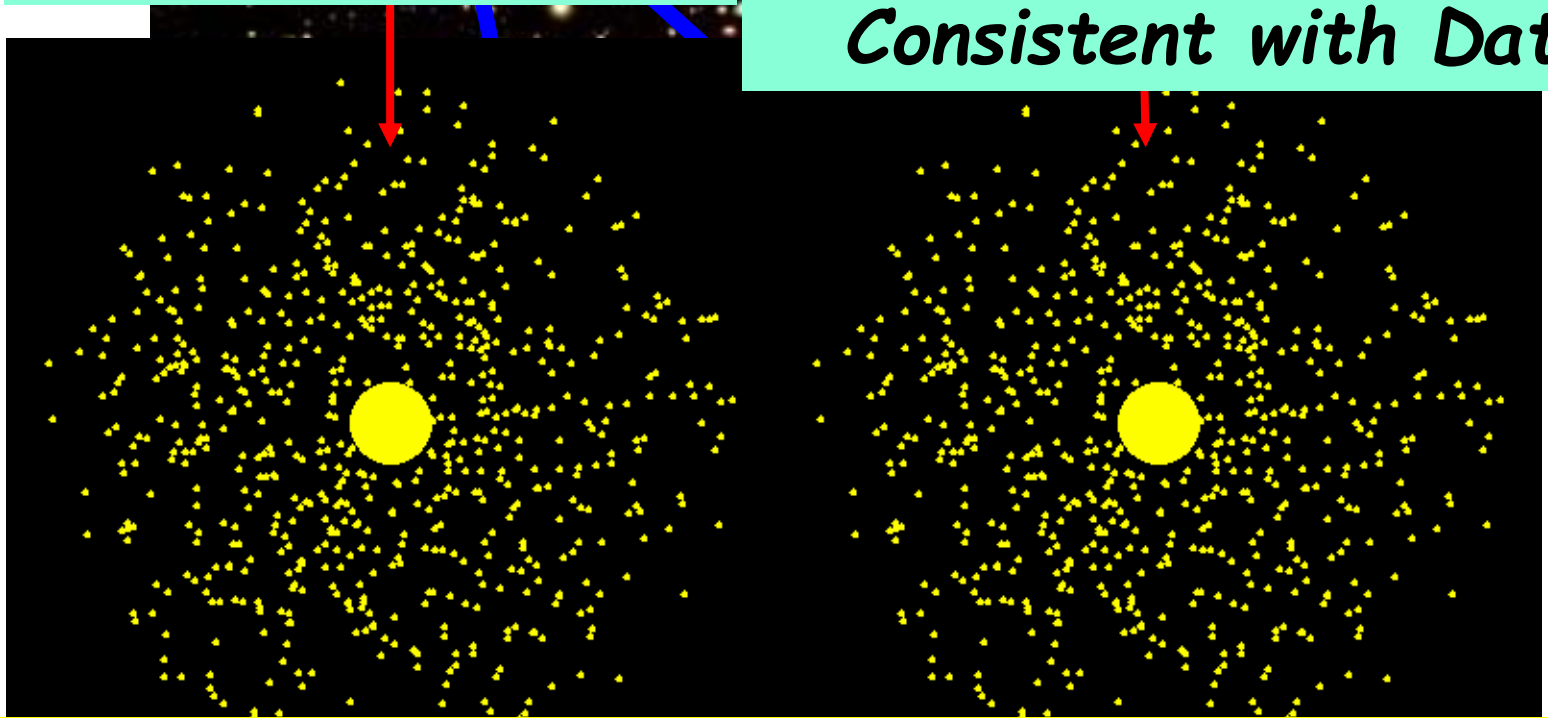

Galaxy Rotation Simulation with and without Dark Matter

The Known Particles

- No known particles have the properties of Dark Matter
- Other credible reasons to believe there are new fundamental particles to be discovered
- None experimentally verified, but lets take a look at our best bet

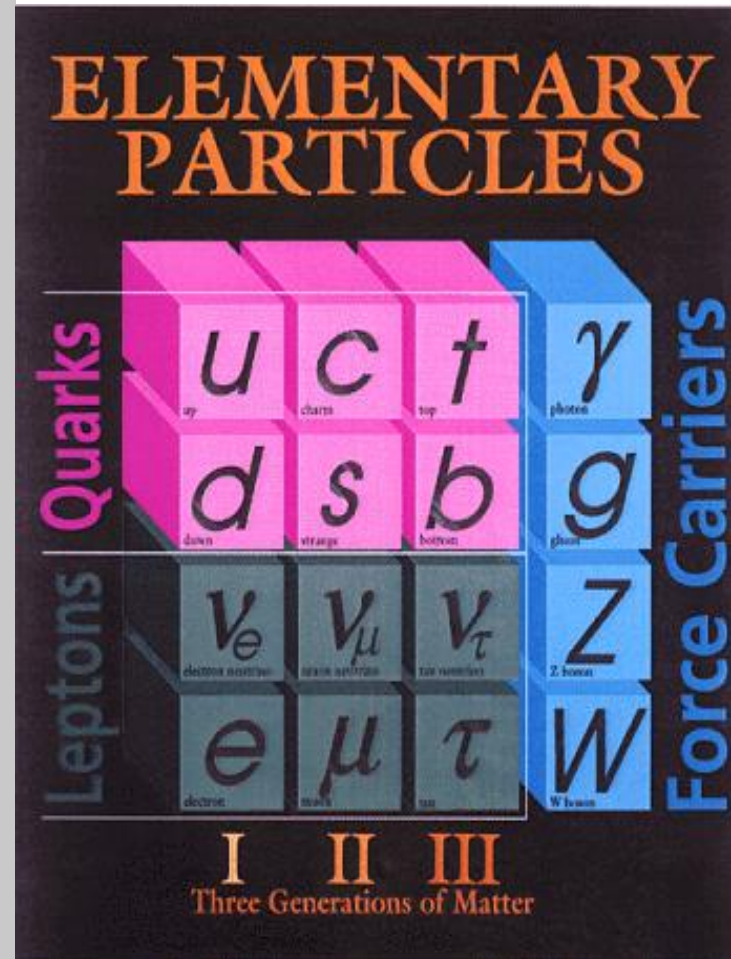

Why Focus on Supersymmetry?

There are some theories that are so compelling that it's worth doing a comprehensive and systematically deep set of searches to see if they are realized in nature

→ Supersymmetry is such a theory

Also predicts Dark Matter



First things
First: What is Supersymmetry and why do we care?

What is Supersymmetry?

Supersymmetry (SUSY) is a theory that postulates a symmetry between fermions and bosons

$$Q|\text{Boson}\rangle = |\text{Fermion}\rangle$$

$$Q|\text{Fermion}\rangle = |\text{Boson}\rangle$$

Minimal Supersymmetric Standard Model (MSSM)

Standard particles



Quarks \rightarrow Squarks



Gauge Bosons \rightarrow Gauginos



Leptons \rightarrow \tilde{S}

The gaugino states mix
 \rightarrow Refer to them as
Charginos and Neutralinos

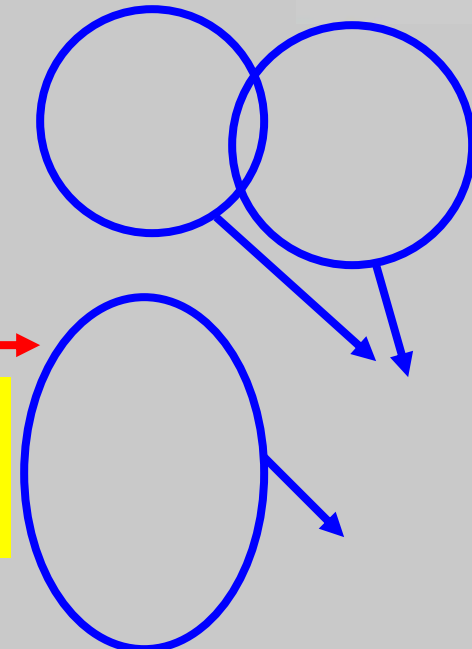

Advantages and Disadvantages of SUSY

- There is no unique explanation of the origin of the sparticle masses or couplings
 - With all these new couplings and particles it's possible we could have our known SM particles decaying through loops
 - Any version that predicts/allows a quick proton decay is clearly wrong
 - Any version that has the same mass for the particles and the sparticles must be wrong
 - Haven't observed any bosonic electrons in nature
 - $m_{\text{positron}} = m_{\text{electron}} \neq m_{\text{selectron}}$
- SUSY is broken somehow

Different Ways to Proceed

- There is no unique explanation of the symmetry breaking \rightarrow need to make some assumptions
- Can put in masses and couplings by hand
 - General SUSY has over 100 new parameters
- Use experimental constraints and theoretical prejudices to further restrict the parameter space
 - To protect the proton lifetime can define R-parity = $(-1)^{3(B-L)+2s}$ and assert that it's conserved
 - $\rightarrow R = 1$ for SM particles
 - $\rightarrow R = -1$ for MSSM partners
- R-Parity violating terms would also have to be small for lepton number violation and still allow neutrino mixing

SUSY can provide a Dark Matter Candidate

If R-Parity is conserved then the lightest SUSY Particle can't decay and, if neutral

→ Provides an excellent dark matter candidate

Provides the tie between Dark Matter, Cosmology and Particle Physics?

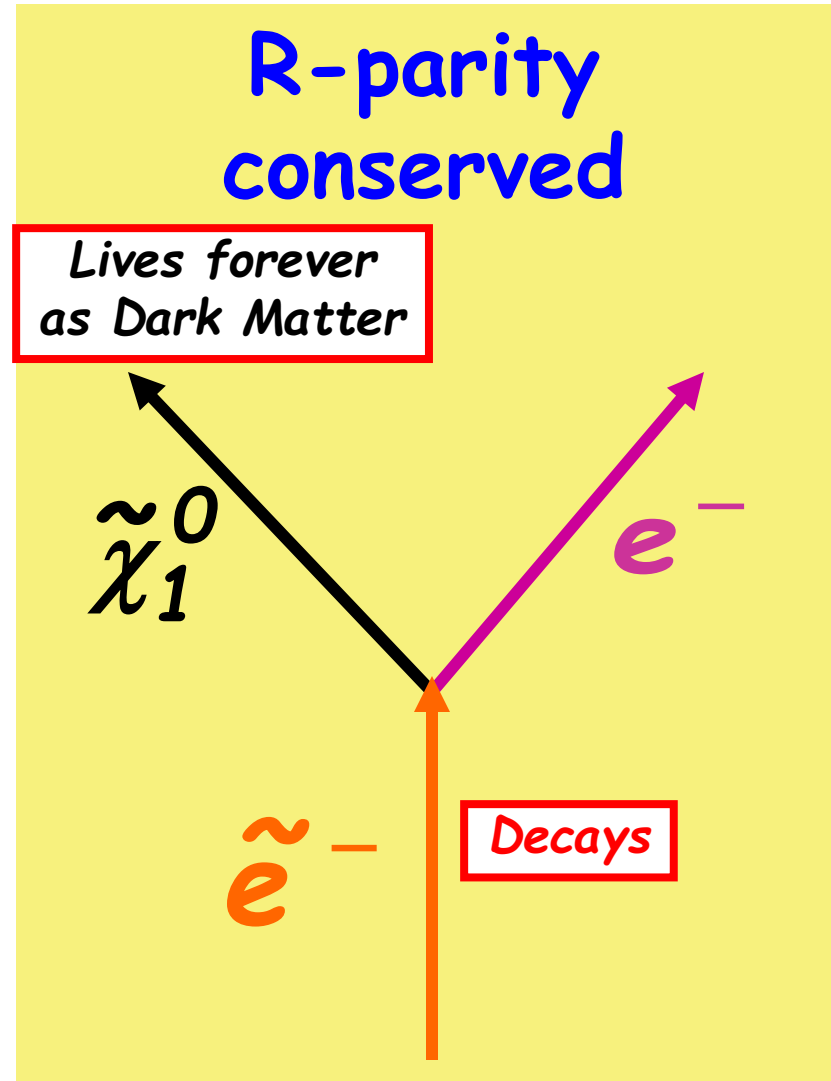

Particle Physics solution to an Astronomy/Cosmology problem?

- **Good:** Predict massive stable particles that explain Dark Matter effects
- **Better:** Provide both a model of particle physics and cosmology that is consistent with Early Universe Physics and evolves into the observed amount of Dark Matter today

Dark Matter = Supersymmetric Particles?

Astronomy, Cosmology and Particle Physics:
The Dark Matter in the Universe is made up of LOTS of particles

Big Bang!
Then Universe gets bigger
... still here today!



$10^{15}C^{\circ}$
 $10^{-16}sec$

Dark matter



SUSY provides a full calculation

Not good enough to simply provide a candidate, need to describe early Universe physics and correctly predict the Dark Matter relic density

Different Types of SUSY Solutions

Cold Dark
matter
(~100 GeV)
Produced in
the Early
Universe



Warm Dark
matter
(~1 keV)
Produced
later in time



Sparticle Masses and Lifetimes
deeply affect the particles in
the Early Universe and Today

Collider Physics

How does Collider Physics Help us Answer These Questions?

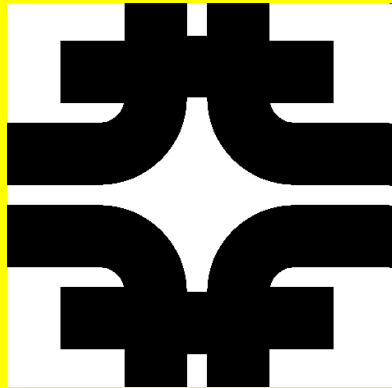

Tevatron at
Fermilab



LHC at
CERN

Can we Make and Discover Dark Matter?

- High energy collisions between particles in the Early Universe
- Recreate the conditions like they were **RIGHT AFTER** the Big Bang
- If we can produce Dark Matter in a collision then we can **STUDY** it

High Energy Collisions → New particles

Tevatron → ≈ 10 ps after the Big Bang

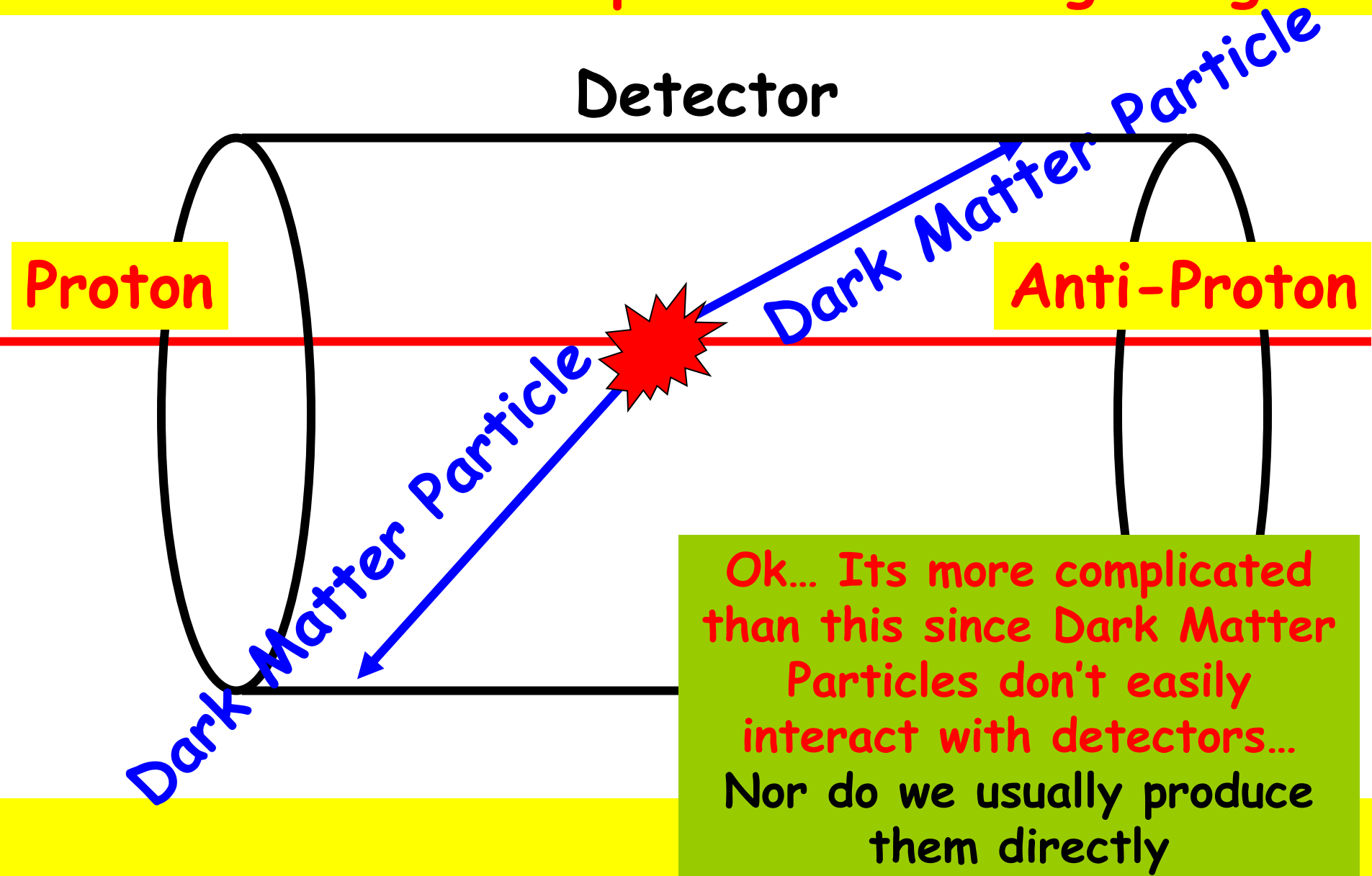

Today: Fermilab



Today: Fermilab Tevatron

The Tevatron is the high Energy Frontier until LHC turn-on

- Proton anti-proton collisions

- 2.5 million collisions per second

Rumours of running until 2012 depending on the LHC schedule



Inside the Accelerator

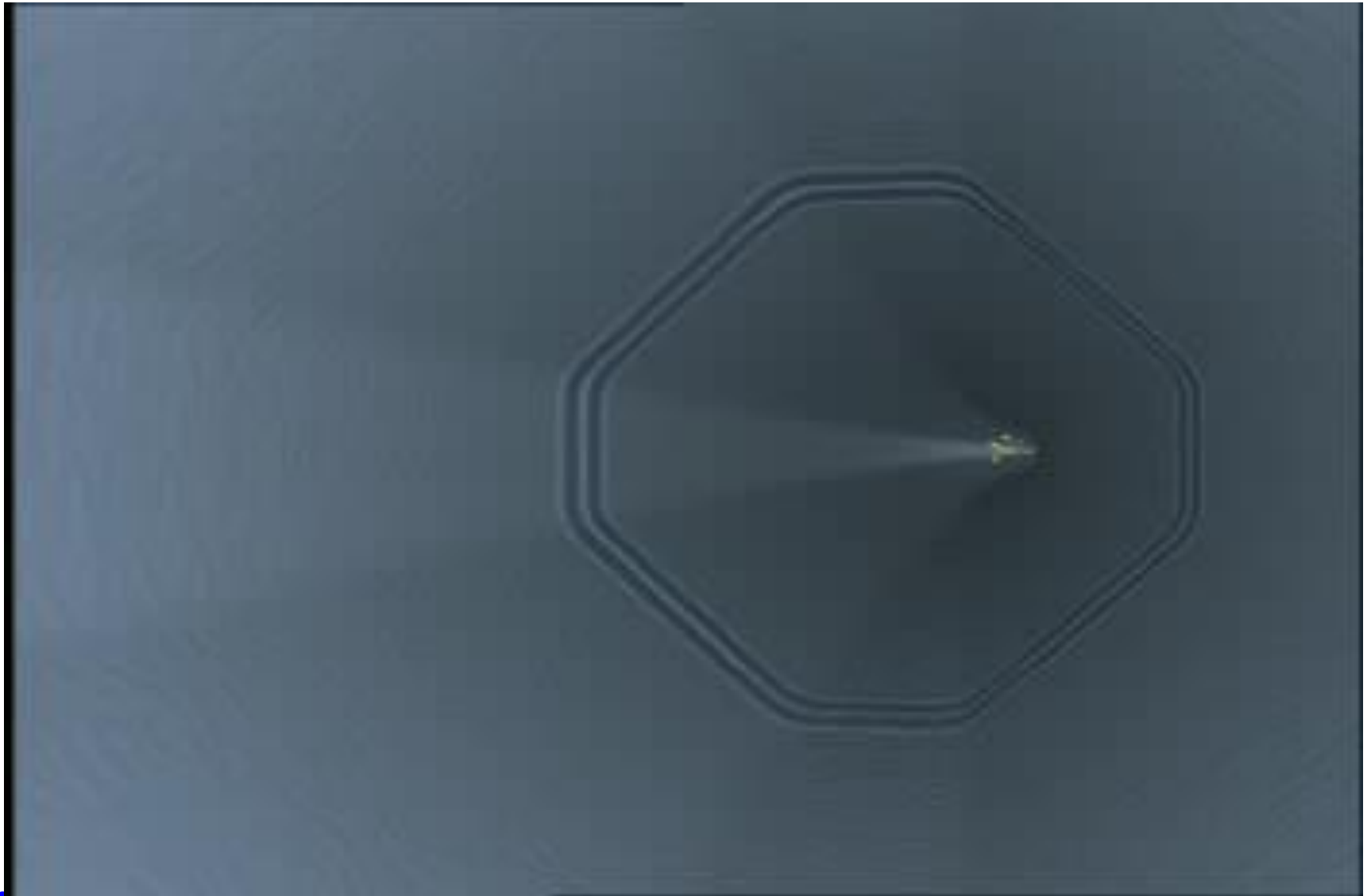

The CDF Detector

10 Meters Tall!
30 Meters Long!

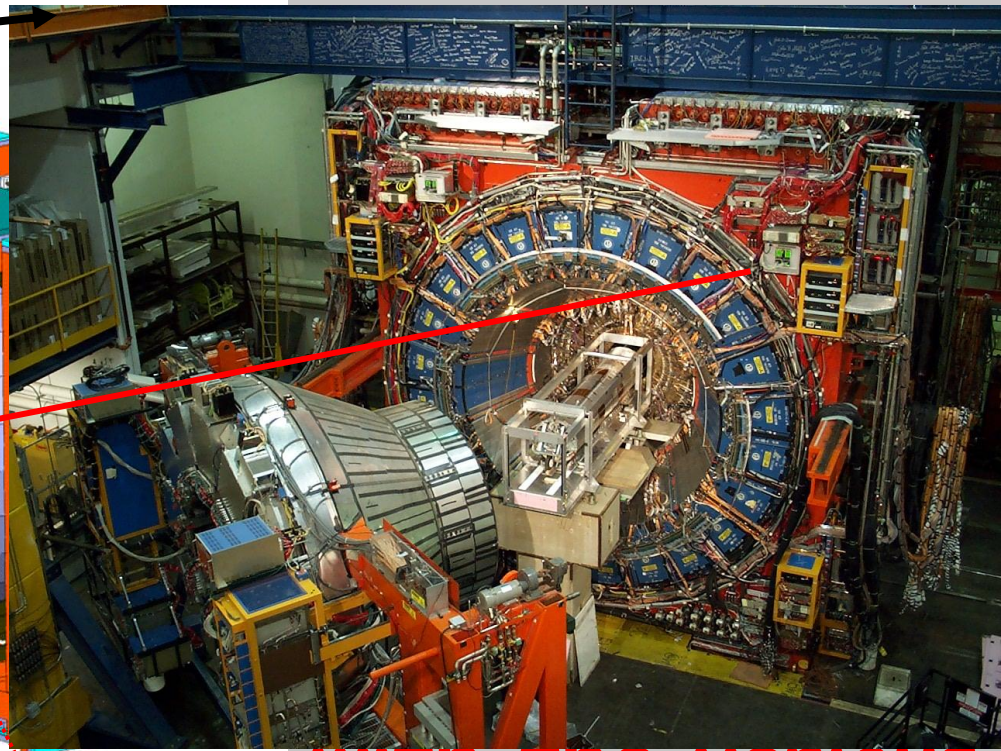
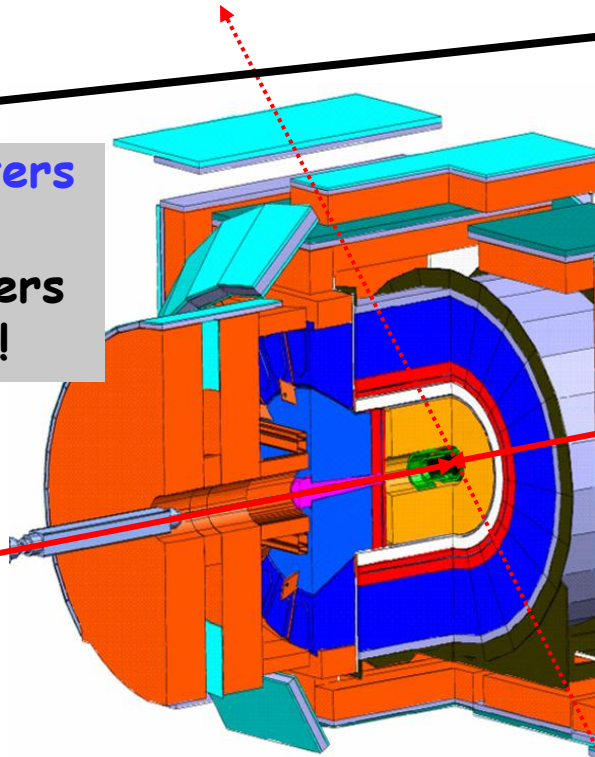

**WITH THE VARIOUS
Powerful multi-purpose
detector**
**High quality identification
of all the Standard Model
particles**

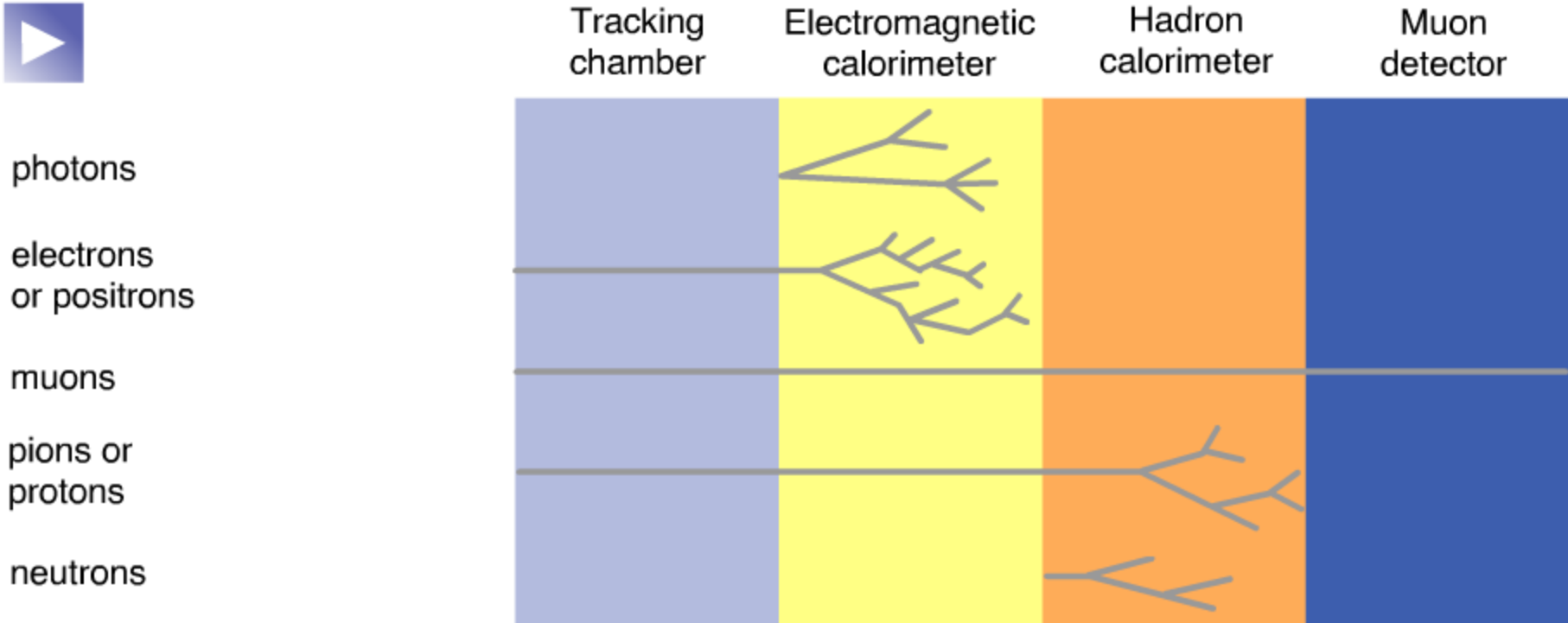

Neutrinos and Dark Matter Don't Interact with the Detectors

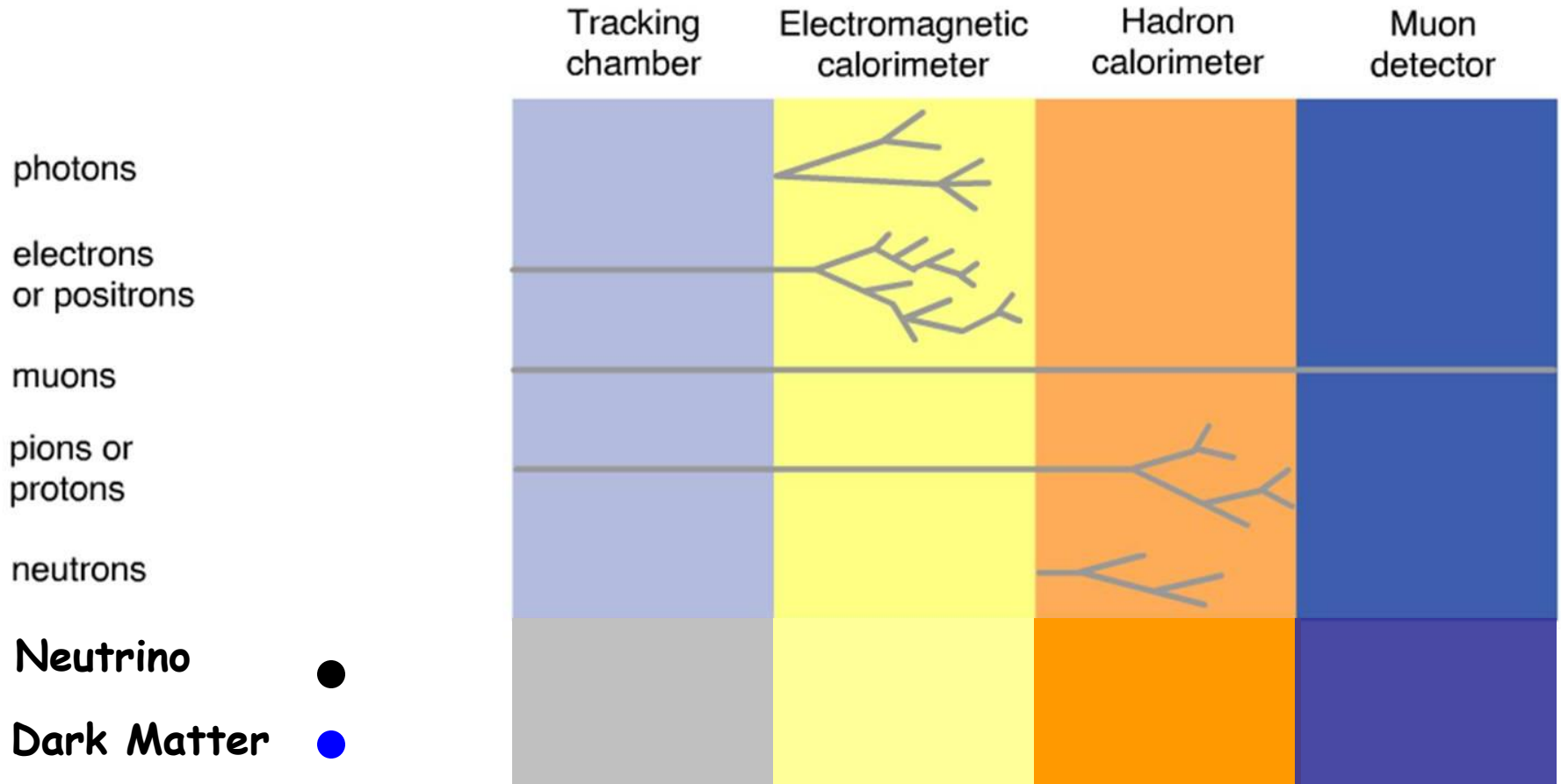

High Energy Collisions \rightarrow Standard Model Particles

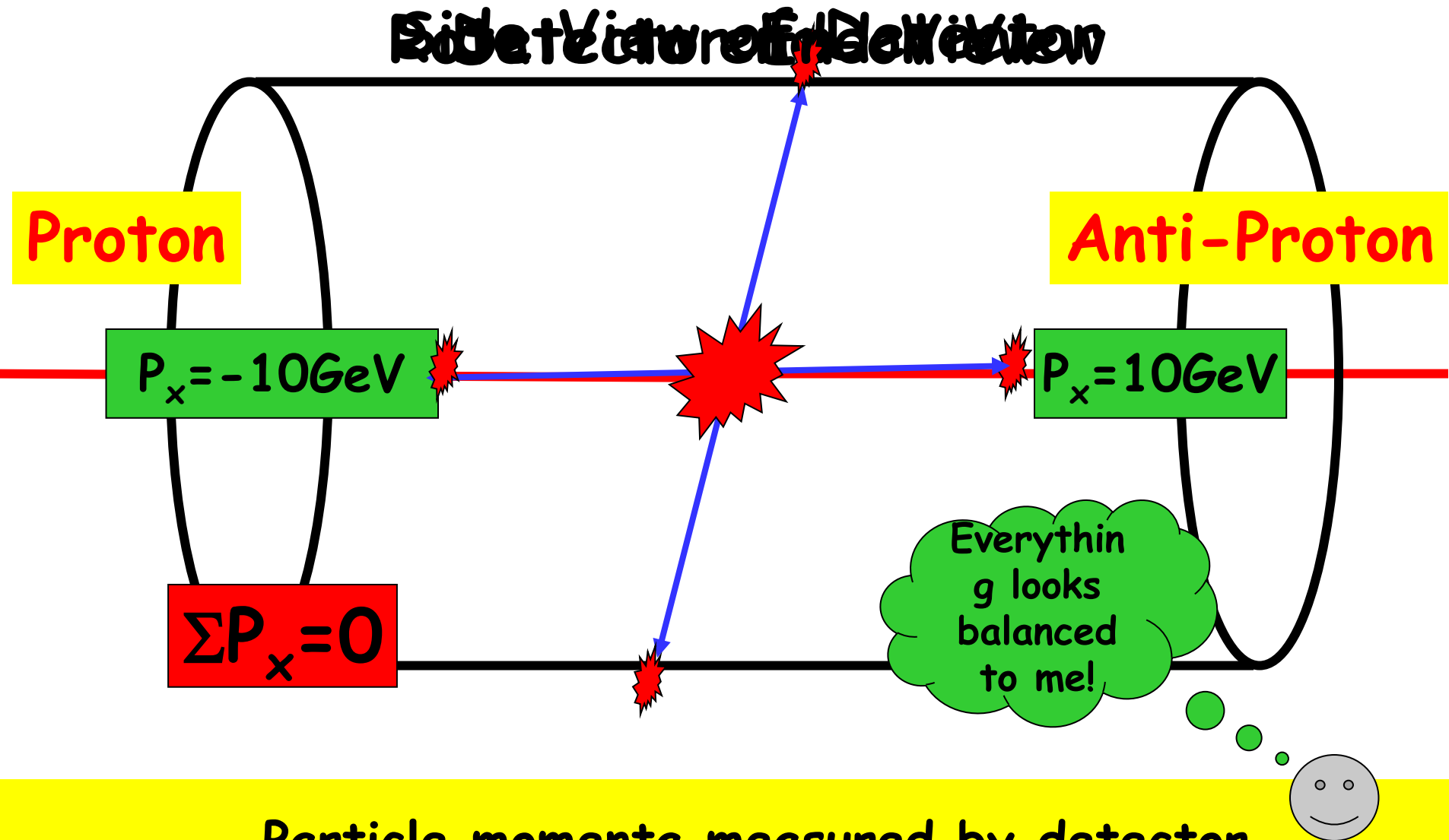

A Dark Matter and a SM particle at the same time?

$\Sigma P = -10 \text{ GeV}$
in the x -direction
→ Missing Energy!
Smoking Gun for Dark Matter

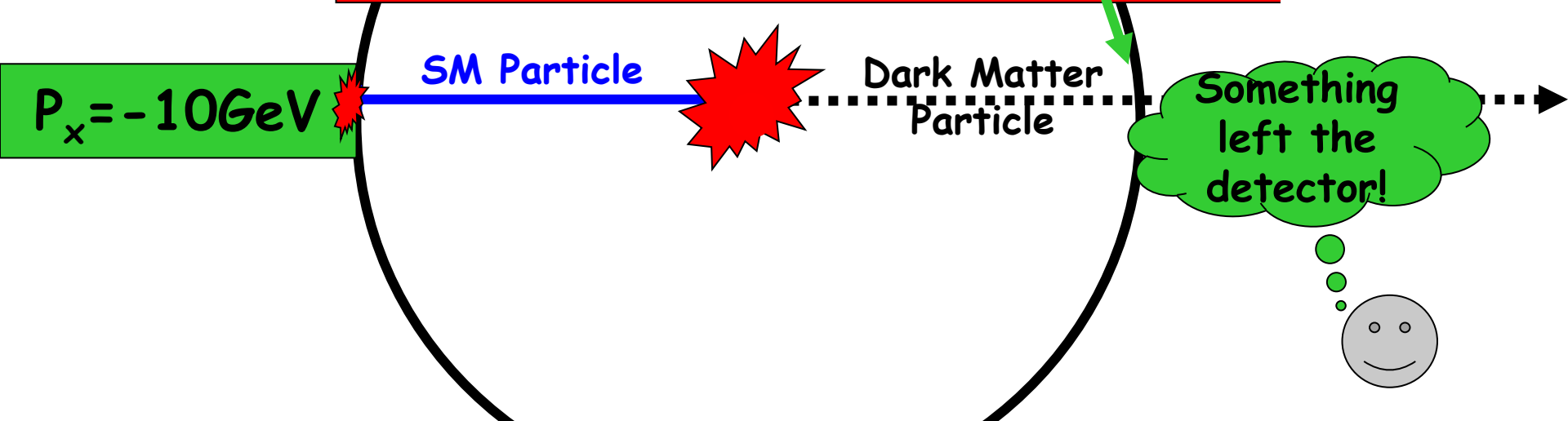

SM Particle Deposits energy, but Dark Matter particle doesn't interact with the detector and leaves

Standard Model: Supersymmetry:

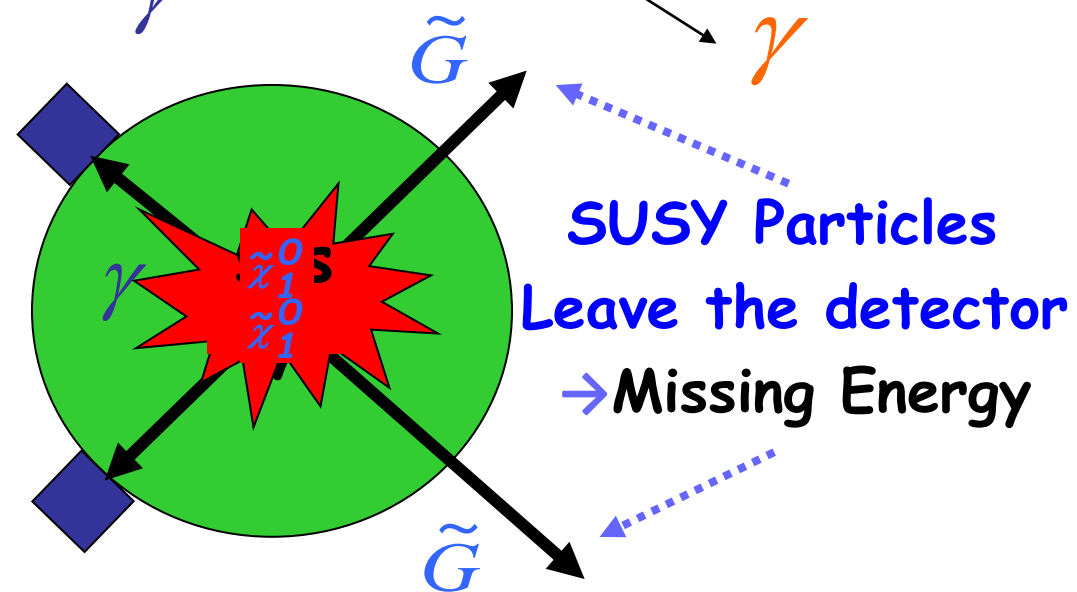
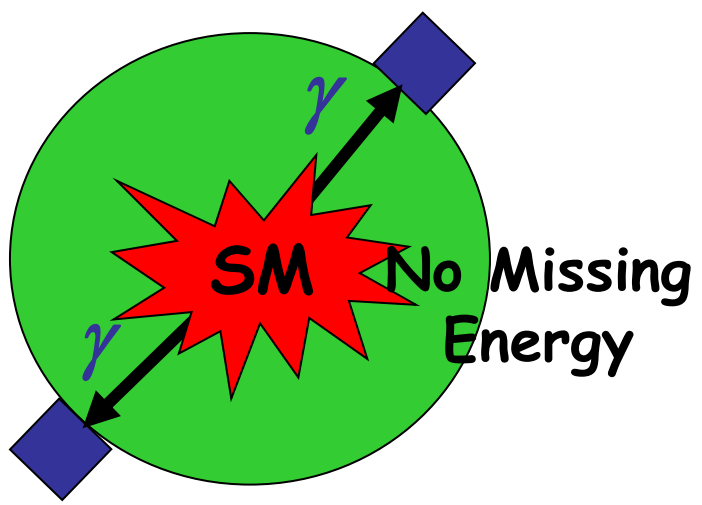
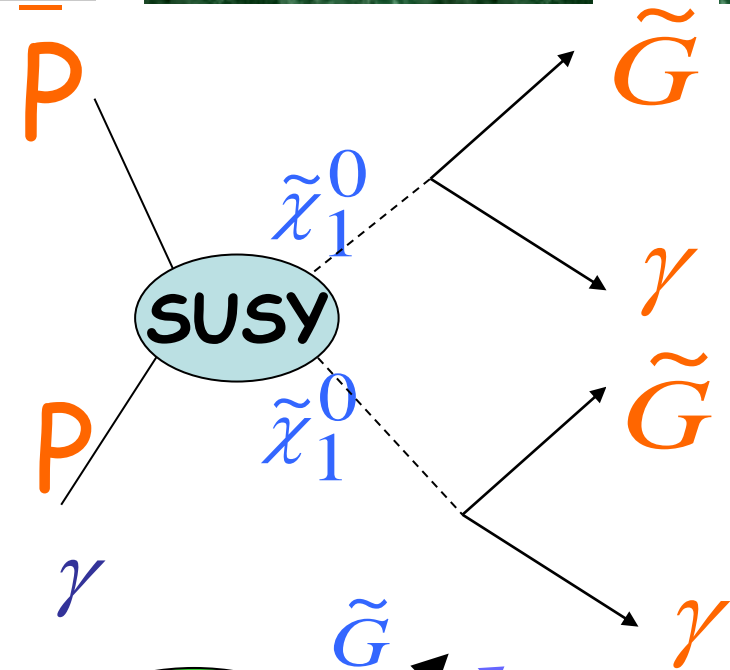
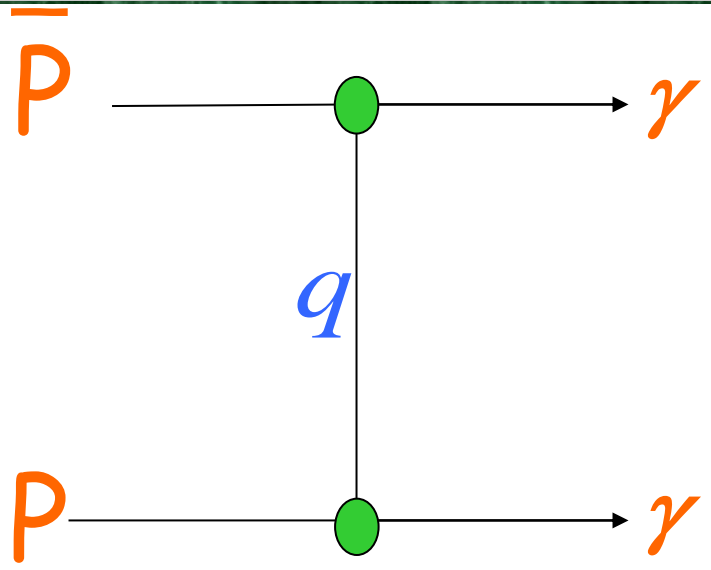

Going from Collisions to experimental results

Look at lots of collisions (call them events) and identify the ones that pass the "Dark matter Identification Requirements"

$$N_{\text{events}} = \text{Luminosity} \times \sigma_{\text{production}} \times \text{Acceptance}$$

How many collisions (events) pass all our requirements

How many proton anti-proton collisions happened

How often a proton anti-proton collision produces a SUSY event

How well the detector does at detecting SUSY events

Number of background events from Standard Model Sources follows the same procedure

Signal Vs. Background

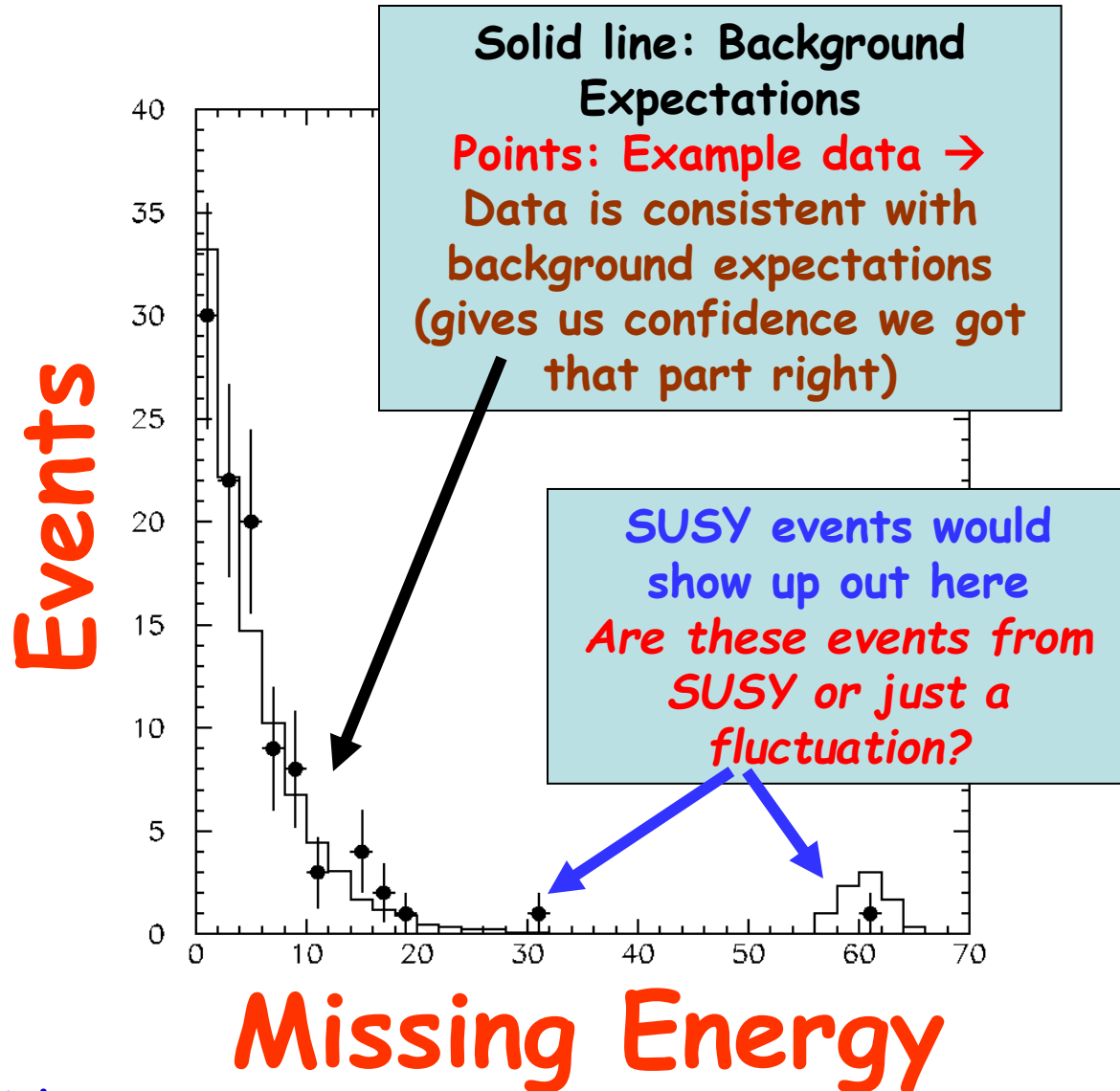

- Look at each event
- Put the measured missing energy in a histogram
- Compare the expected predictions from Standard Model and from SUSY

Outline of the Searches

- **Cold Dark Matter Searches**

- Squarks & Gluinos
- Gaugino Pair Production

- **Warm Dark Matter Searches**

- Short and long-lifetimes



The Sparticle Masses in Cold Dark Matter Scenarios

In a typical Cold Dark Matter type scenario

- Squarks and gluinos are heavy
- 1st and 2nd generation squarks are mass degenerate
- The lightest neutralino is the LSP
 - Dark Matter candidate

In some important versions the Stop, Sbottom and Stau can get much lighter

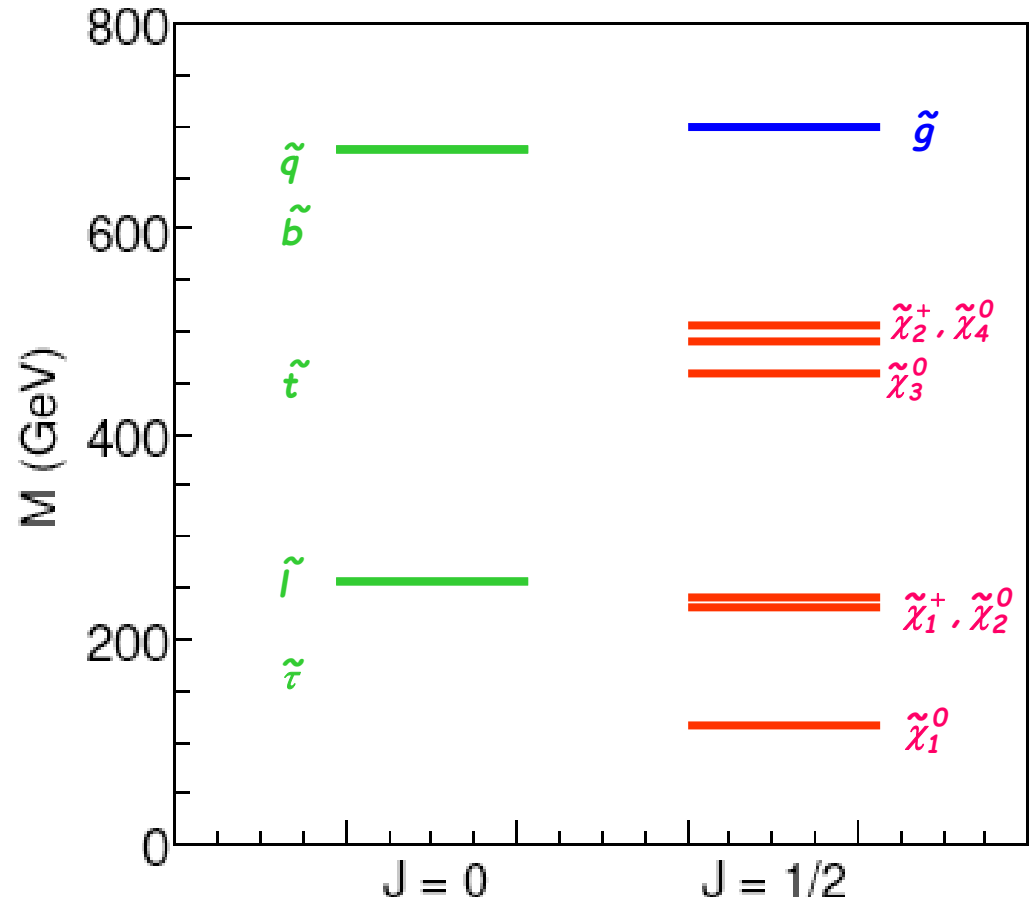

Golden Search Channels

Three main ways to look for minimal models with Cold Dark Matter Models

- Direct production of Squarks and Gluinos
 - Heavy, but strong production cross sections
- Direct production of the Gauginos
 - Lighter, but electroweak production cross sections, also leptonic final states have smaller backgrounds
- Indirect search via sparticles in loops
 - Affect branching ratios

Move on to the
results from me and
about 700 of my
closest friends at
Fermilab...

T. Aaltonen,⁴⁸ J. Adelman,¹⁴ T. Akimoto,²⁰ M. G. Albrow,¹⁸ B. Alvarez González,¹⁴ S. Amerio,^{48,x} D. Amidei,²²
A. Anastassov,³⁹ A. Annovi,²⁰ J. Antos,¹⁵ G. Apollinari,¹⁸ A. Apresyan,⁴⁹ T. Arisawa,⁵⁸ A. Artikov,¹⁶ W. Ashmanskas,¹⁸
A. Attal,⁴ A. Aurisano,⁵⁴ F. Azfar,⁴³ P. Azzurri,^{47,y} W. Badgett,¹⁸ A. Barbaro-Galtieri,²⁹ V. E. Barnes,⁴⁹ B. A. Barnett,²⁶
V. Bartsch,³¹ G. Bauer,³³ P.-H. Beauchemin,³⁴ F. Bedeschi,⁴⁷ P. Bednar,¹⁵ D. Beecher,³¹ S. Behari,²⁶ G. Bellettini,^{47,x}
J. Bellinger,⁶⁰ D. Benjamin,¹⁷ A. Beretvas,¹⁸ J. Beringer,²⁹ A. Bhatti,⁵¹ M. Binkley,¹⁸ D. Bisello,^{44,x} I. Bizjak,³¹
R. E. Blair,² C. Blocker,⁷ B. Blumenfeld,²⁶ A. Bocci,¹⁷ A. Bodek,⁵⁰ V. Boisvert,⁵⁰ G. Bolla,⁴⁹ D. Bortoletto,⁴⁹
J. Boudreau,⁴⁸ A. Boveia,¹¹ B. Brau,¹¹ A. Bridgeman,²⁵ L. Brigliadori,⁴⁴ C. Bromberg,³⁶ E. Brubaker,¹⁴ J. Budagov,¹⁶
H. S. Budd,⁵⁰ S. Budd,²⁵ K. Burkett,¹⁸ G. Busetto,^{44,x} P. Bussey,^{22,aa} A. Buzatu,³⁴ K. L. Byrum,² S. Cabrera,^{17,s}

Aside before we begin...

Most analyses will look like they were easy

Noto Bene: It's 2009 and we're 8 years into running

This is a lot harder than it looks and it takes a lot longer than it should

I'll try to comment periodically on lessons for LHC

"It's a lot of work to make it look this easy"
- Joe DiMaggio



- Yogi Berra

Squark and Gluino Searches in Multijet + Met

Three main production diagrams
Final states are mass dependent

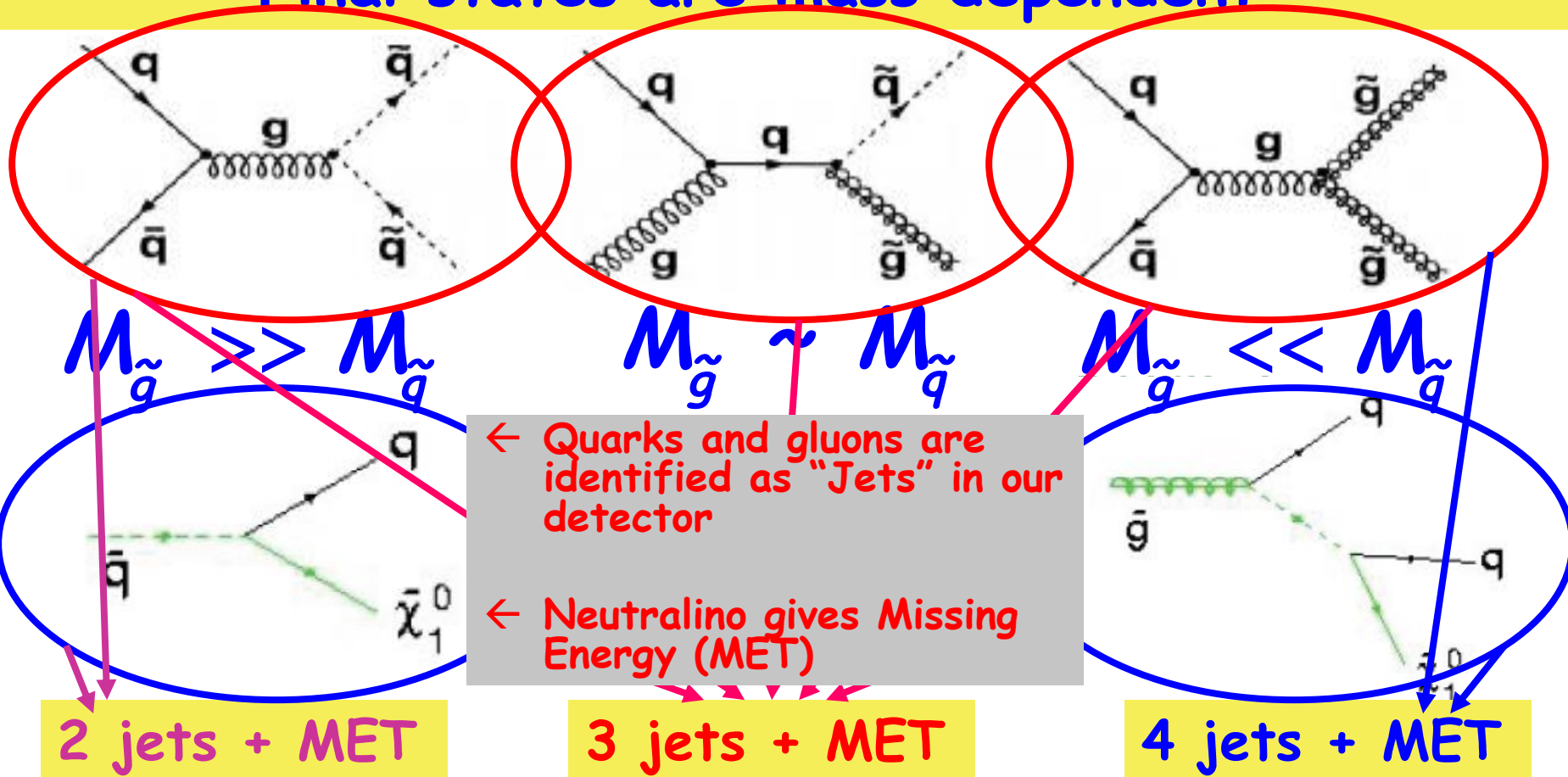

Multiple final states + Unified Analysis → best coverage

Unified Squark/Gluino Search

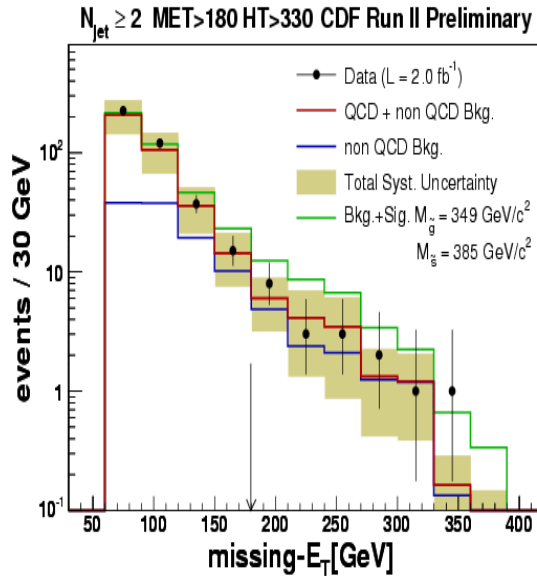

2 jets + MET

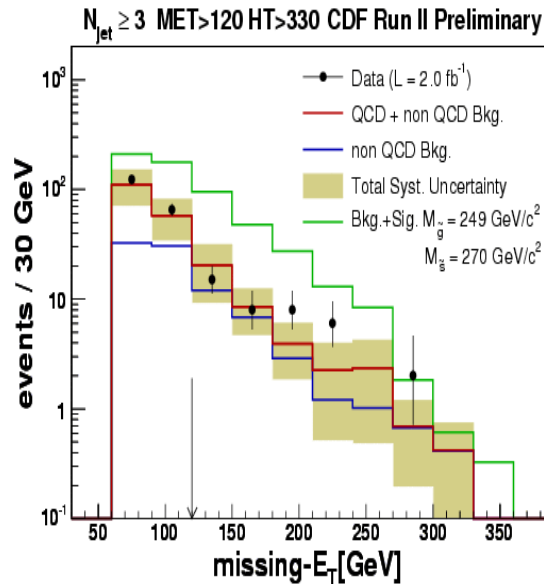

3 jets + MET

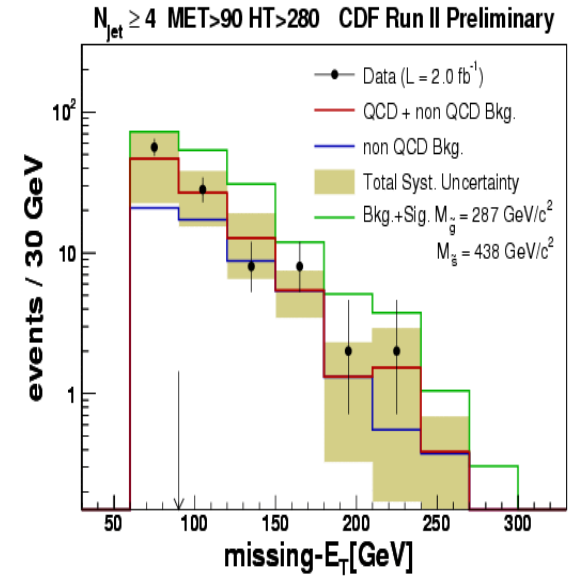

4 jets + MET

No evidence for new physics

SUSY Interpreter Set Cross Section Limits

As with most CDF results, there are comparable $D\bar{D}$ results which I won't touch on

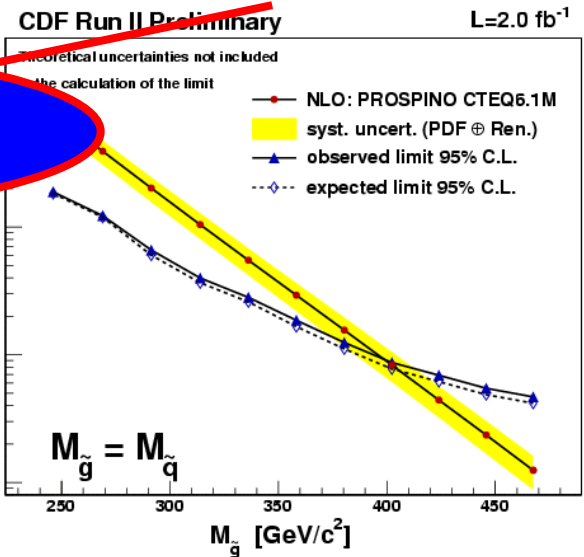

More limits...

You see Hobbs, I can Transmogrify the cross section results into limits on the Sparticle Masses

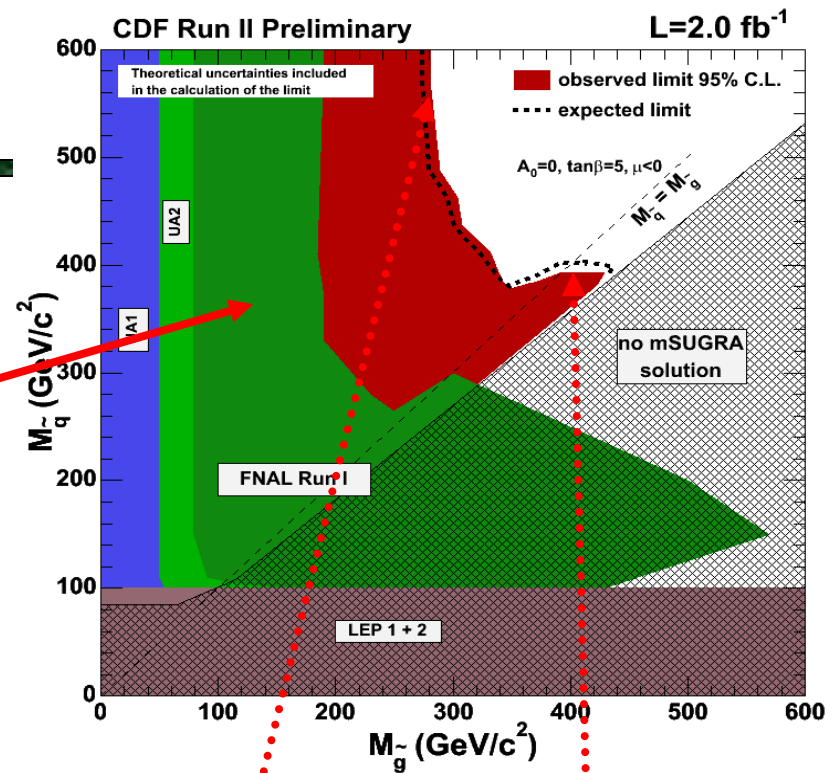

$M_g < 280 \text{ GeV}$ always excluded
 $M > 392 \text{ GeV}$ when $M_g = M_q$

Sbottom Searches

Two primary Sbottom searches in ***b+jets+Met***

1. Sbottoms from gluinos
2. Direct sbottom pair production

Special tricks to identify *b*-quarks from their long lifetime

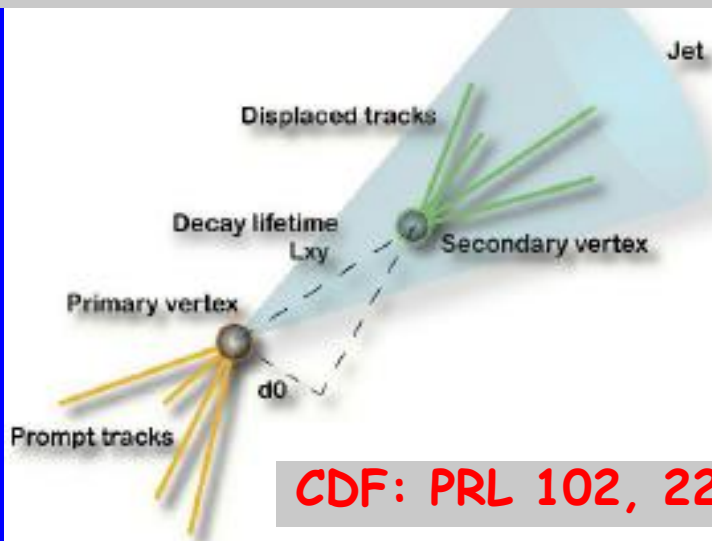

CDF: PRL 102, 221801 (2009)

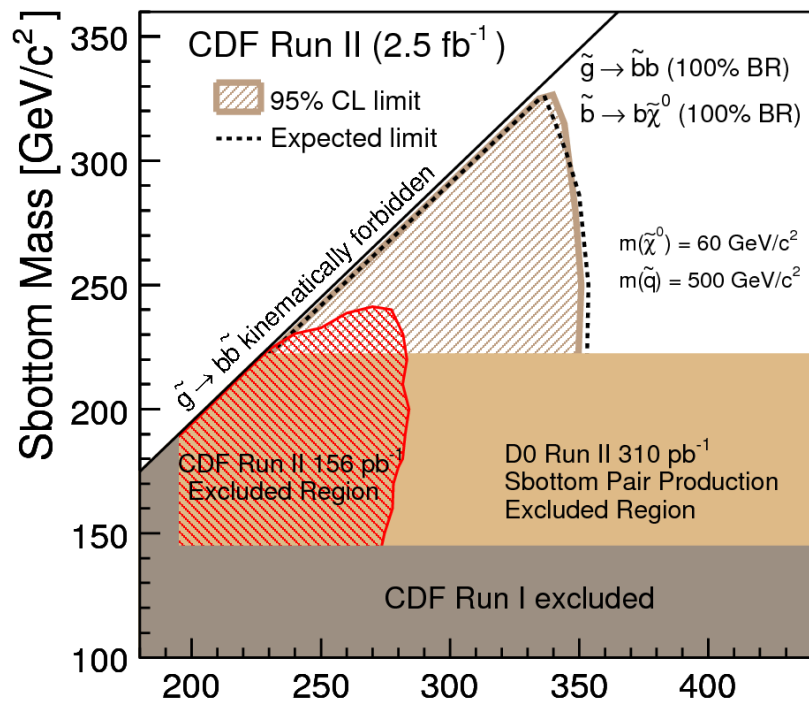
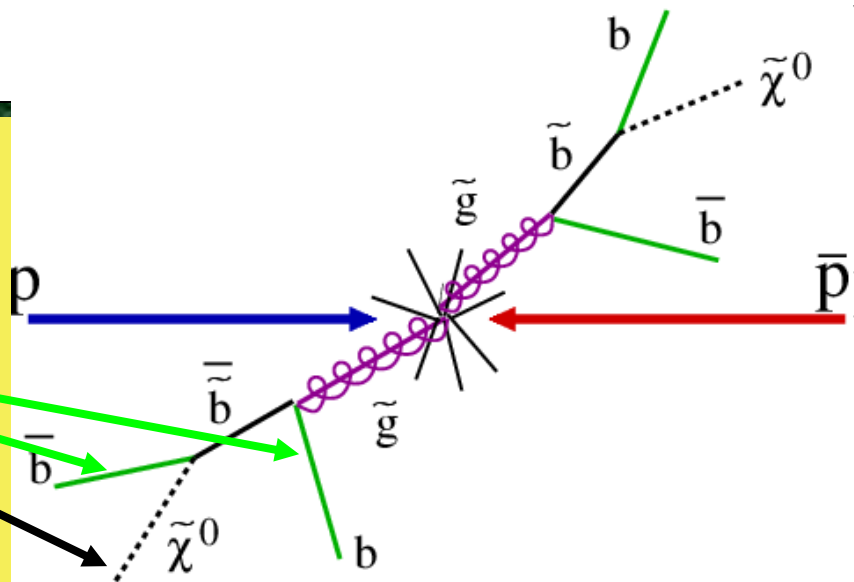

Gluino Mass [GeV/c^2]

Lightest Squark = Stop?

Lots of Analyses

Direct Counting Experiments and Sophisticated Fitting Methods

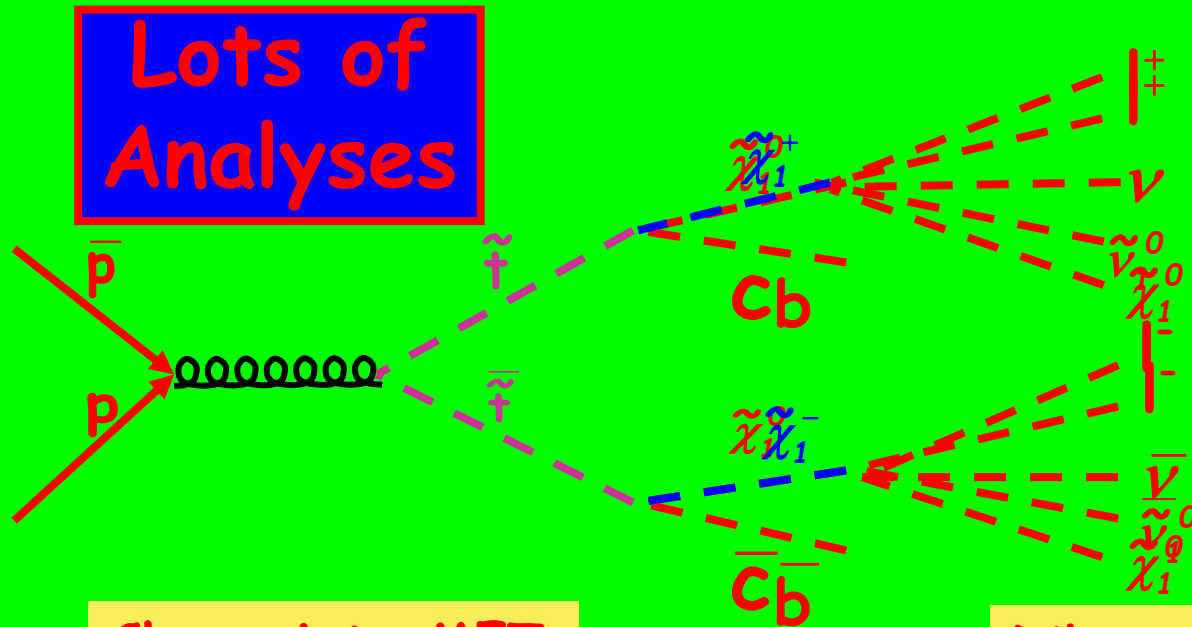

Charm jets+MET

Dileptons+Jets+MET

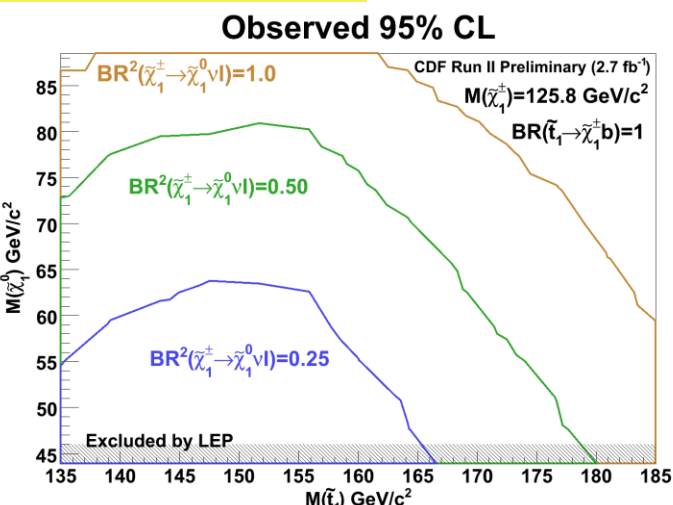
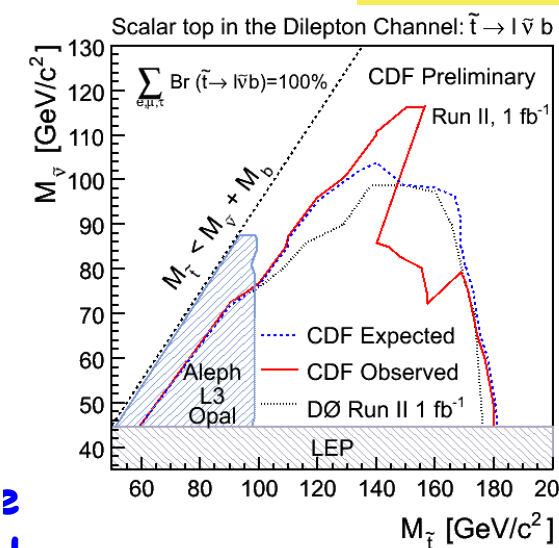
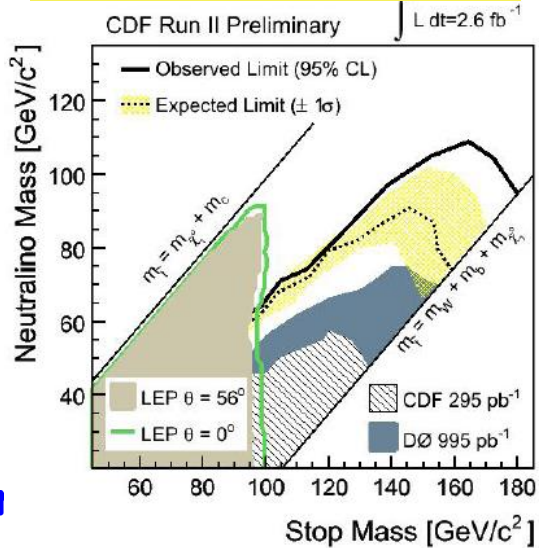

Gaugino Pair Production

Chargino-Neutralino gives three low energy leptons in the final state

Dominates the production cross section

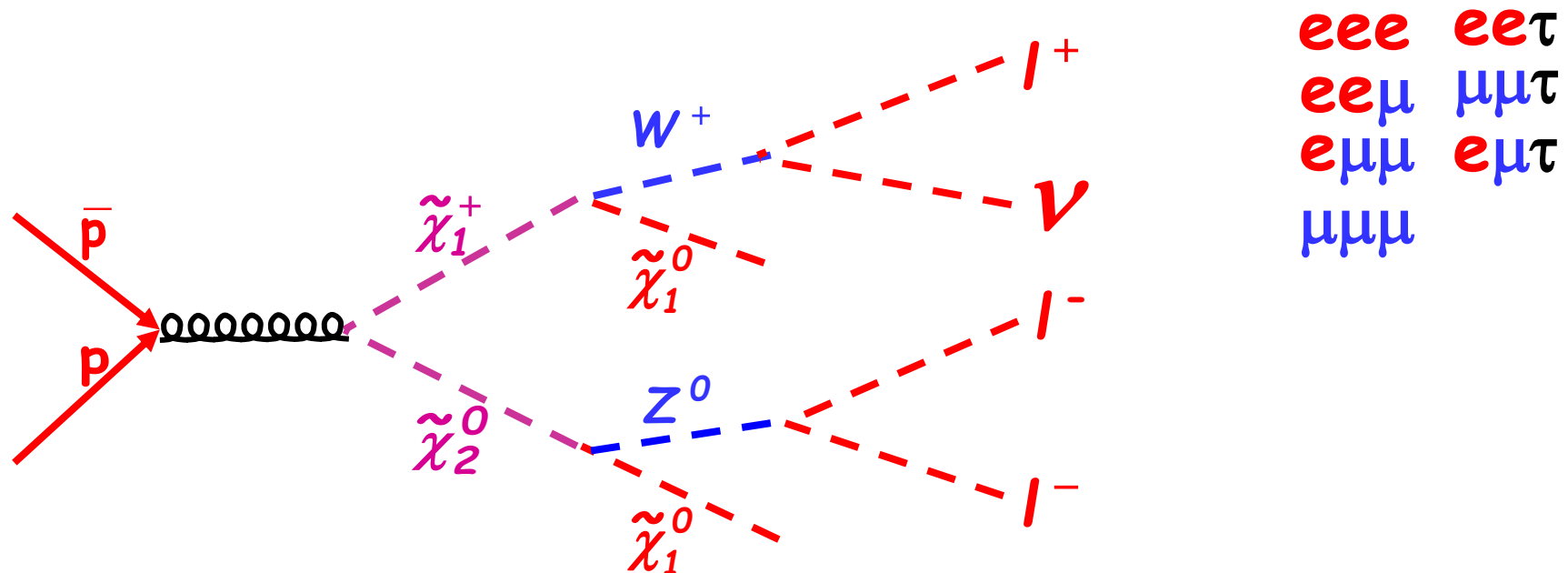

Lots separate final states + Unified Analysis \rightarrow best coverage

SUSY in Trilepton Events?

No evidence for SUSY or Dark Matter so set limits...

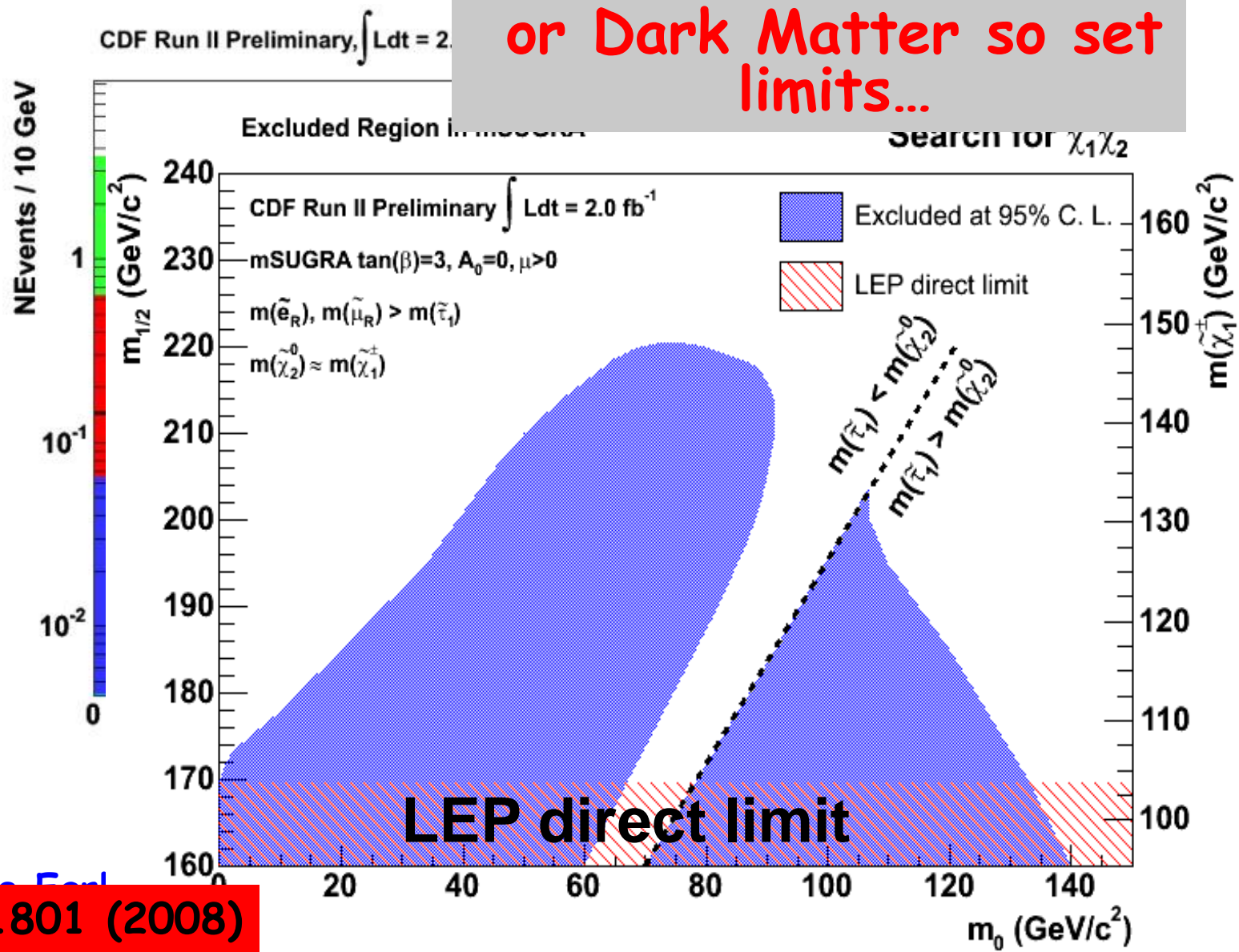

Warm Dark Matter Models

$\tilde{\chi}_1^0 \rightarrow \gamma \tilde{G}$ models provide a warm dark matter candidate consistent with astronomical observations and models of inflation

Provides alternative solutions for other particle physics problems

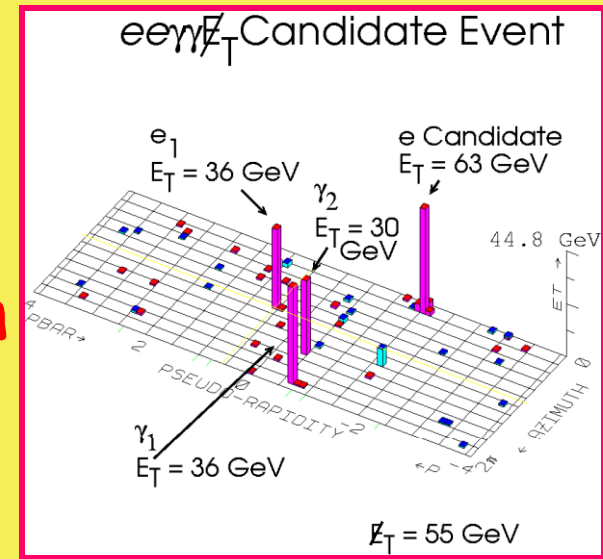

CDF Run I $e e \gamma \gamma + \text{Met}$ candidate event

Early Universe

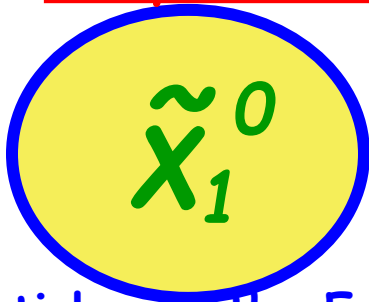

Nanosecond lifetimes



Later Universe

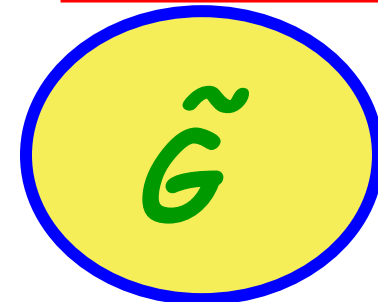

Warm Dark Matter

High and Low Lifetime Searches

The lifetime and associated particle production dictate different final states

- $\gamma\gamma$ +Met for small lifetime
- Delayed Photon +Met for large lifetime

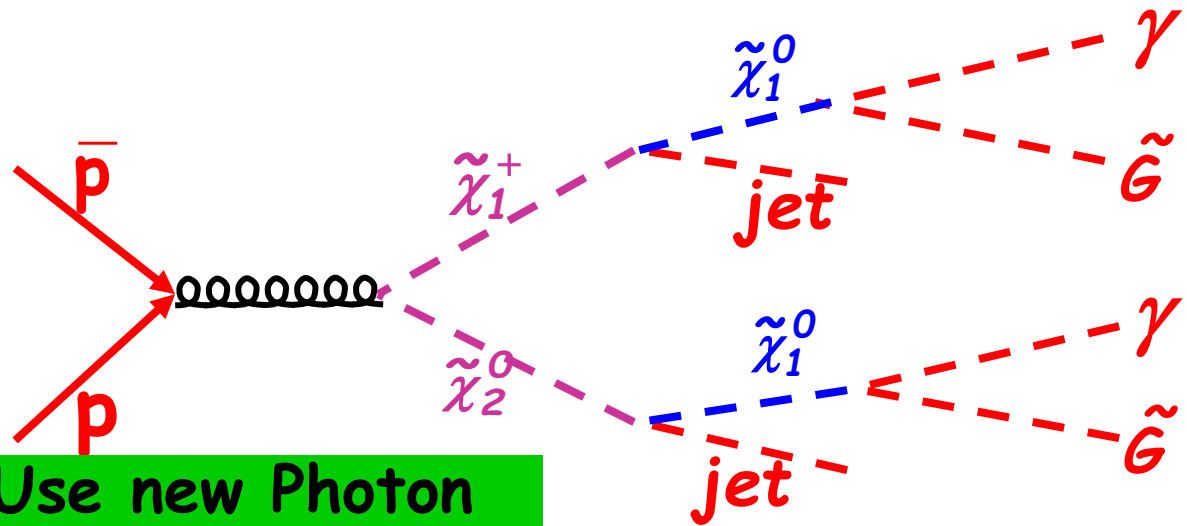

Use new Photon Timing system

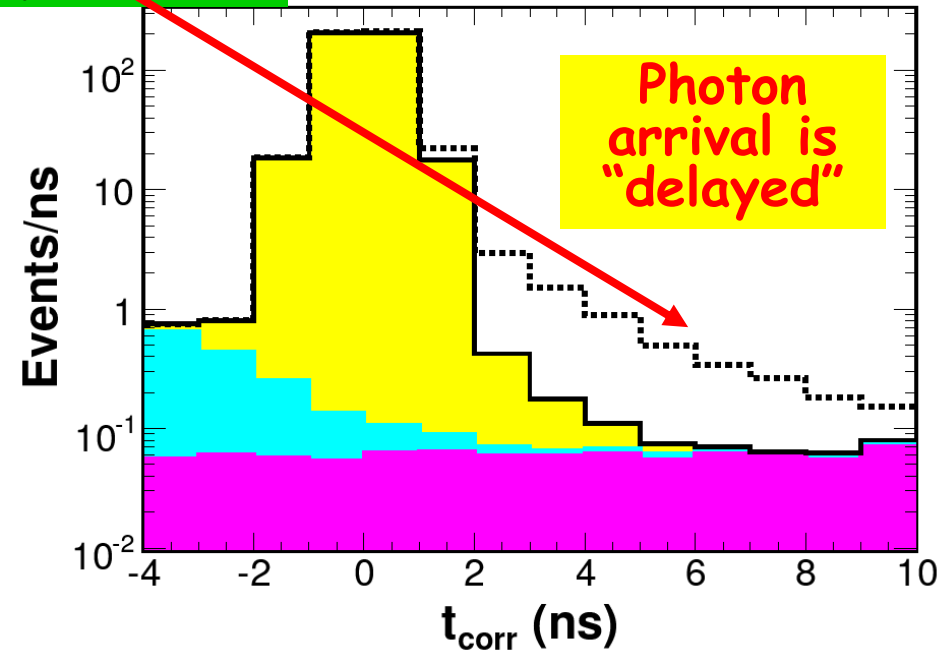
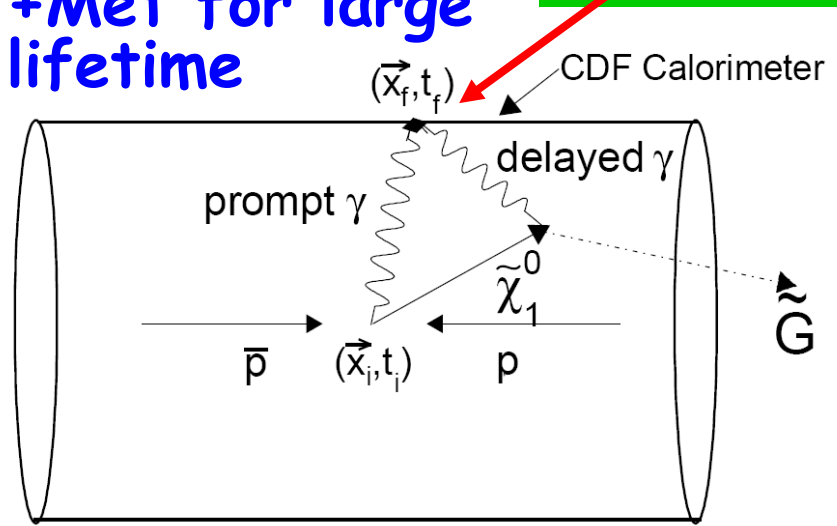

Low lifetime Neutralinos

Optimize the $\gamma\gamma + \cancel{E}_T$ analysis for 0 ns lifetime:

Significant Met and Large "other energy"

No evidence for new physics

To be submitted to PRL next week

$\gamma\gamma + \cancel{E}_T$ analysis in GMSB

CDF Run II Preliminary, 2.6 fb⁻¹

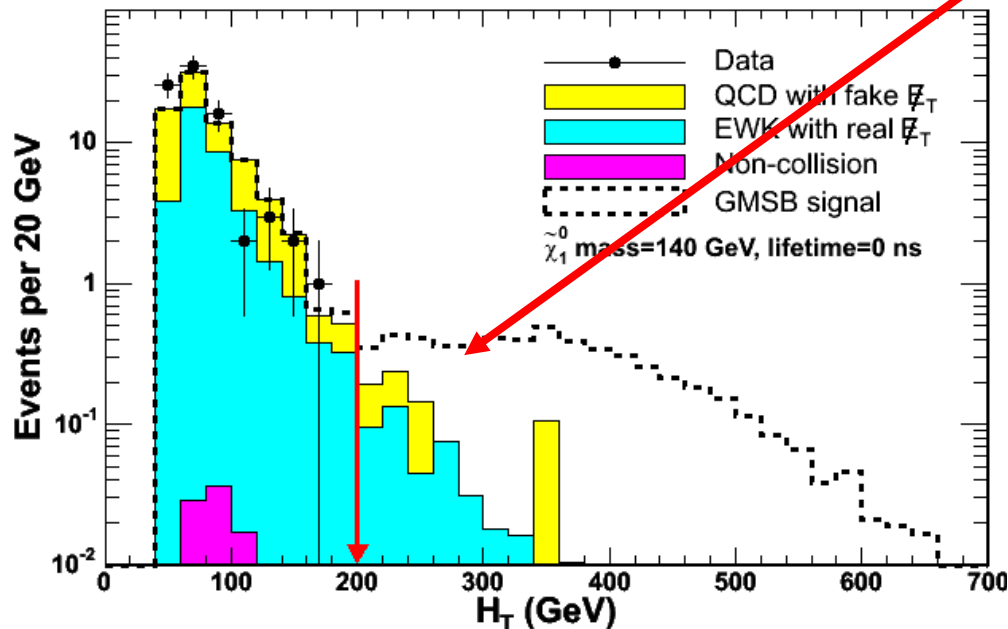

$\gamma\gamma + \cancel{E}_T$ in GMSB

CDF Run II Preliminary, 2.6 fb⁻¹

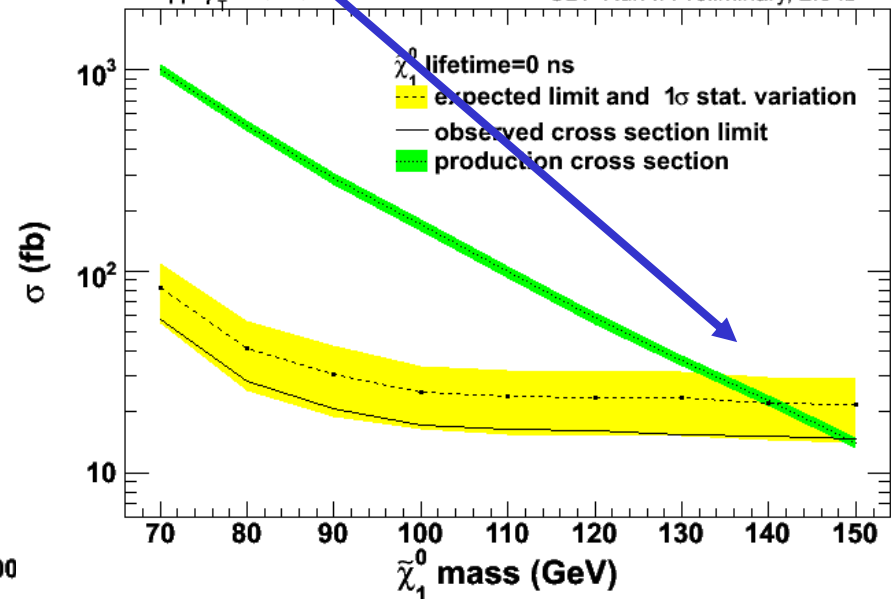

All Neutralino Lifetime Searches

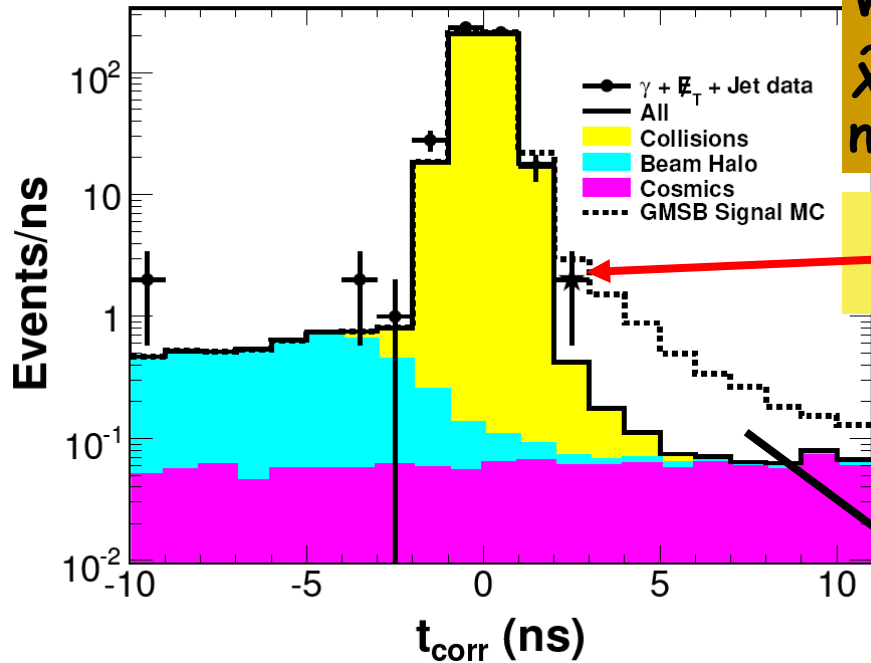

Warm dark matter models of GMSB with $\tilde{\chi}_1^0 \rightarrow \gamma \tilde{G}$ favor keV \tilde{G} masses and nanosecond $\tilde{\chi}_1^0$ lifetimes

Measure the time of arrival of photons in $\gamma + \text{Met} + \text{Jet}$ events

CDF, PRL 99, 121801 (2007)

CDF, PRD 78, 0321015 (2008)

Combine $\gamma\gamma + \text{Met}$ and Delayed Photon Limits
 Set limits for zero and Non-zero lifetimes

Also approaching the Cosmology Favored Region
 10 fb^{-1} gets us well into the Cosmology Favored Region

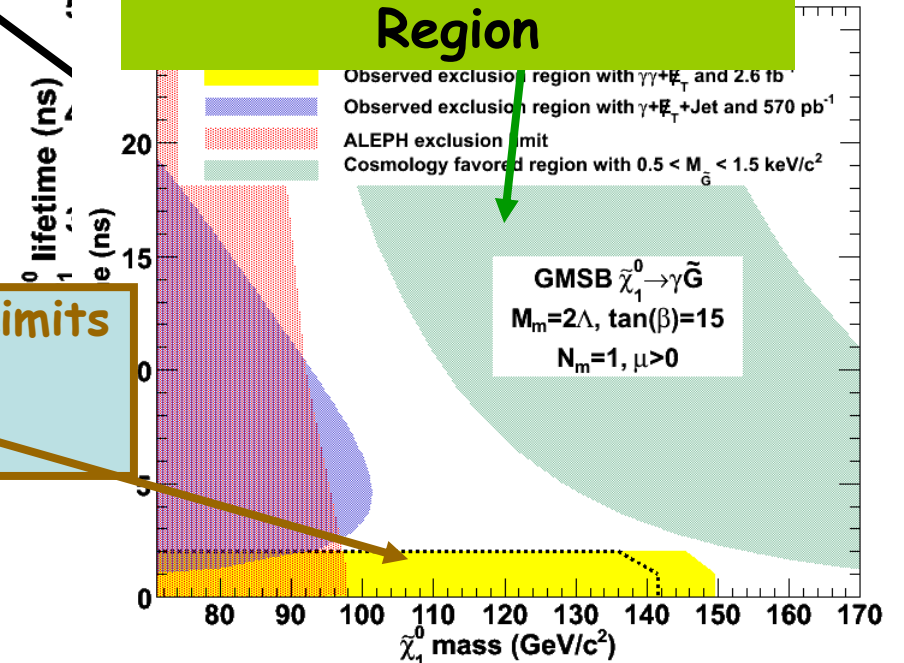

Looking Back and Looking Forward

- Despite a broad and deep search there is no evidence for having produced Dark Matter in Collider Experiments
- Spend a few minutes on other techniques and a look to the future at the LHC

If you believe in minimal Cold Dark Matter Models

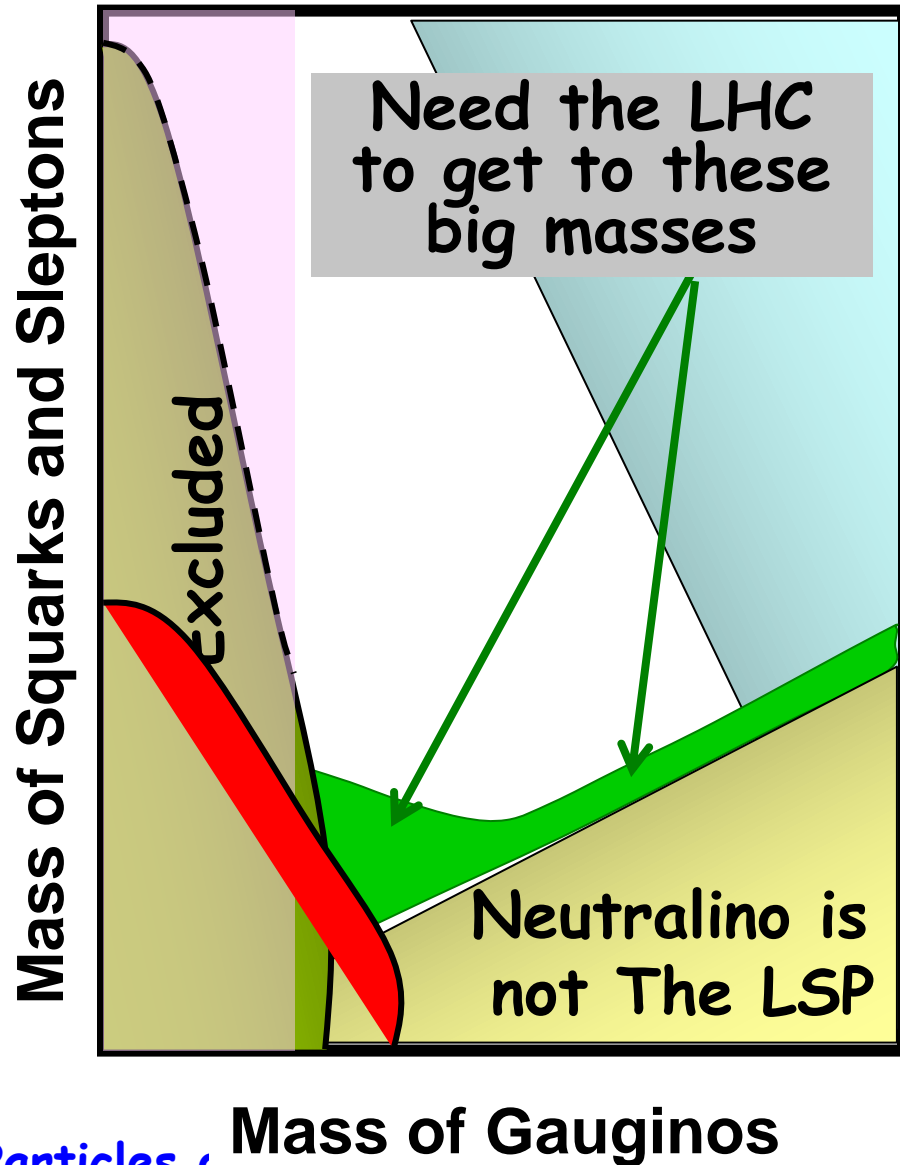

e^+e^- Collider Limits on the Higgs



b -Colliders Indirect:
Branching Ratio $b \rightarrow s\gamma$

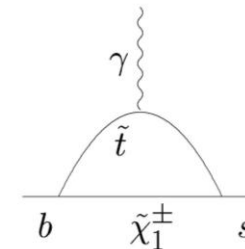

$g-2$: Magnetic Moment of Muon

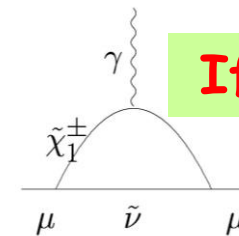

If confirmed...



WMAP Favored region



Tevatron Indirect:
 $B_s \rightarrow \mu\mu$ is most sensitive

From the Tevatron to the LHC

- The Tevatron allows us to look at the conditions of the Early Universe about 1-10 ps after the Bang
 - 100 GeV particles
- The LHC allows us to go about a factor of 10 earlier
 - 1000 GeV particles

Moving to the LHC... Looking Forward

$$N_{\text{events}} = \text{Luminosity} \times \sigma_{\text{production}} \times \text{Acceptance}$$

We will get more data per year!
Then again, none yet...

With higher energy collisions, processes that weren't available before may now be accessible

Backgrounds to the interesting physics will get bigger also

Simulations of both will take awhile to get right

Tevatron:

Not as high energy, but there is lots of data with a beautifully working detector

LHC will be great, but not quick

Important to search today and prepare for tomorrow

With bigger detectors and better technology we should have better sensitivity to interesting events

Understanding how well the detectors will respond to collisions will take awhile

Simulations of signal and background also not vetted

Hypothetical Timeline

With the world's most experienced SUSY-Collider Search Team and a clear vision* let's look in our crystal ball

- 2010-12: First evidence for SUSY particles at LHC
- 2013-15: Establish that we live in a Supersymmetric world
- 2015-2020: Precision measurements of the particle masses \rightarrow compare Dark Matter relic density predictions to those from WMAP
- 20?? Compare to Direct Detection methods \rightarrow Does the SUSY LSP have the same properties as the Dark Matter in the Milky Way?



Combining Particle Physics with Cosmology



*Arnowitt, Dutta, Kamon, D.T., et al., PRL100 (2008) 231802, PLB 649 (2007) 73, PLB 639 (2006) 46

$$\Omega_{\text{SUSY DM}} \stackrel{?}{=} \Omega_{\text{CDM}}$$

Conclusions

The Tevatron has performed a broad and deep set of searches for Dark Matter in the context of Supersymmetry

- Unfortunately, no sign of new physics

Tevatron experiments are performing great and the LHC should enter the race this year

If our understanding of Cosmology and Particle Physics are correct, a major discovery may be just around the corner!



Gaugino Pair Production in Events with Three leptons + Met

Dominates the production cross section

Searches + Unified Analysis → best coverage

Lot of
 $eee, ee\mu, e\mu\mu$
 $e\tau, ee\tau, e\tau\tau$

$eee, ee\mu, e\mu\mu$ & $\mu\mu\mu$

3 TIGHT Leptons + MET

Gauginos Decay dominantly via on-shell sleptons

Typical Trilepton Event

Gauginos Decay dominantly via off-shell W/Z

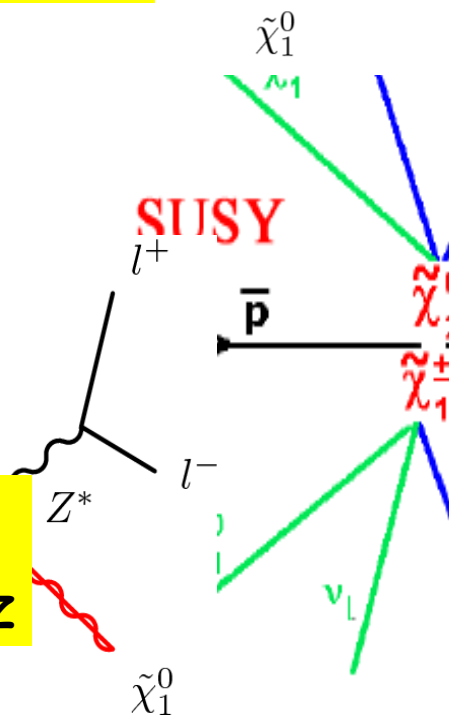
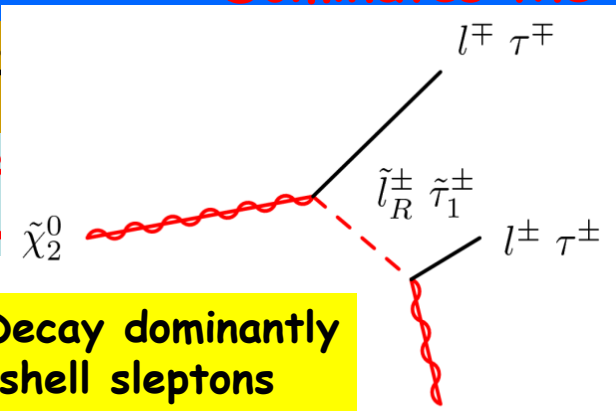

CDF Run II Preliminary, $\int Ldt = 2.0 \text{ fb}^{-1}$

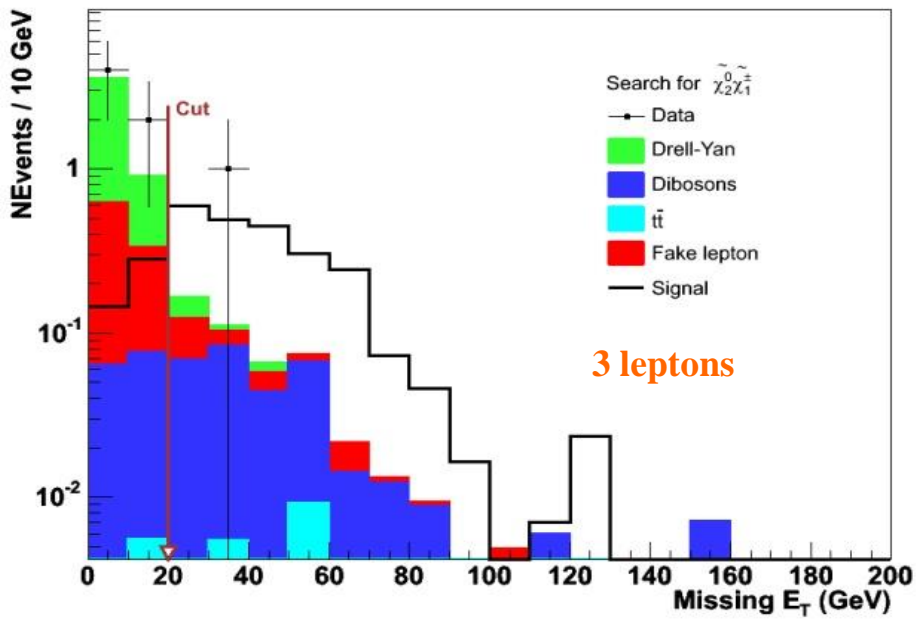

3 leptons

High $\tan\beta$

- Likelihood fits including Higgs mass limits, $g-2$, and other experimental data to the MSSM in the plane of $m_{1/2}$ and $\tan\beta$
 - Prefers high $\tan\beta$
- Stop and Sbottom masses can be very different than the other squark masses
- Gaugino branching fractions to τ 's can rise to 100% as the stau gets light...

Allanach, PLB 635, 123 (2006)

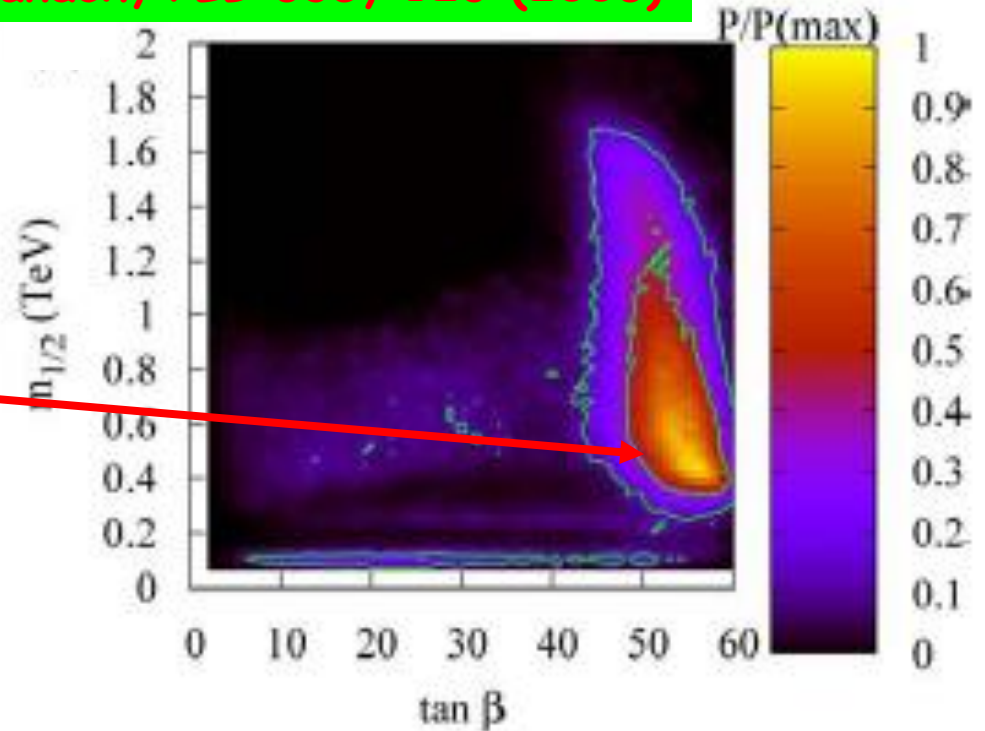

The Tevatron has moved towards having a full suite of high $\tan\beta$ targeted searches

Now look at the head-on view of particles coming out

Detector End-View

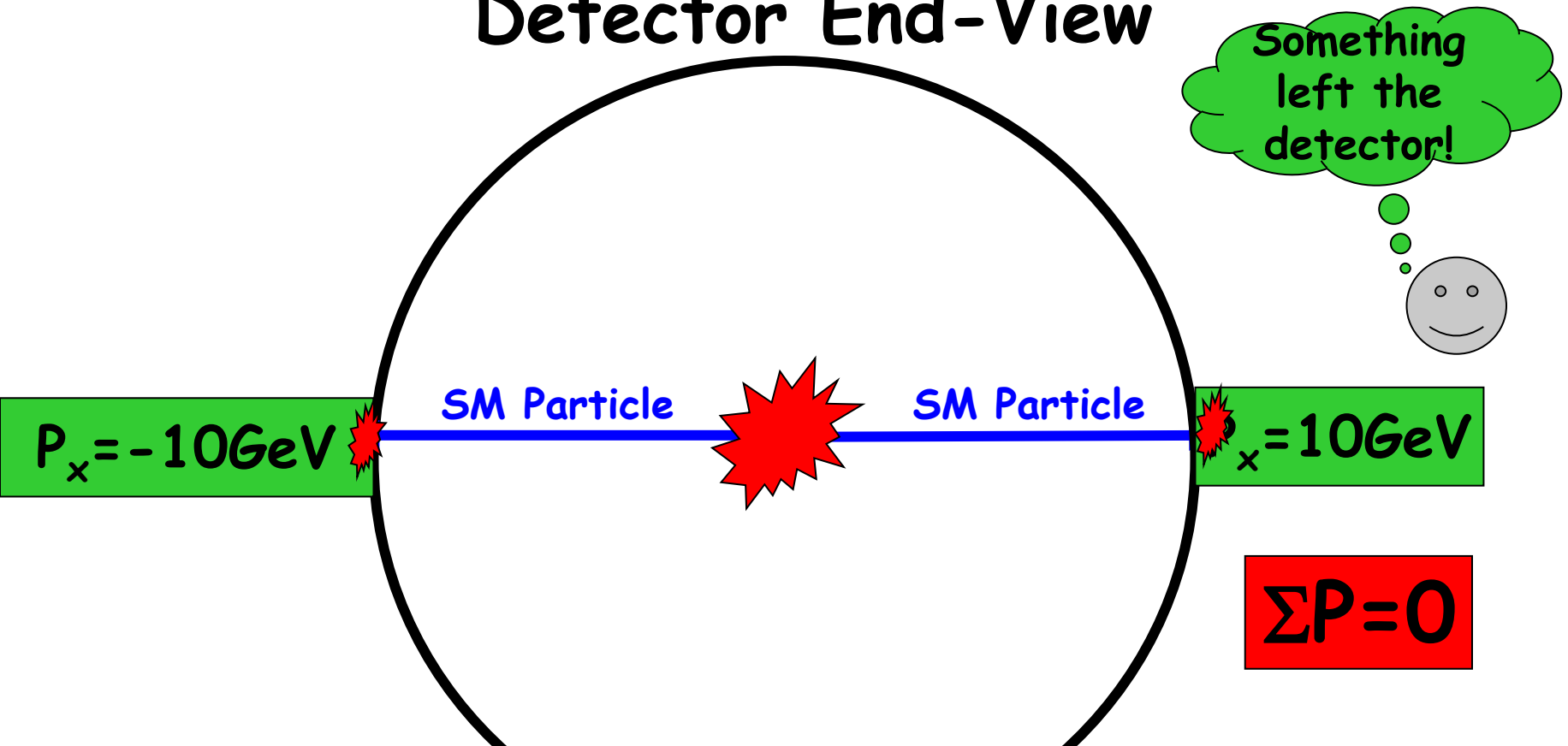

Proton and Anti-Proton Collide in the middle and produce SM particles

Particle momenta measured by detector

Ideas:

- Lots of different ways of looking, use the general principles and look at the high energy frontier.
- If we incorporate more info then perhaps we zoom in to be more sensitive
- One in the hand is sometimes worth two in the bush. Then again if you fail to plan, you are planning to fail.
- Looking to the future, what's the plan?
- Will do the same types of experiments I've shown (I could tell you numbers of masses we would have sensitivity to, but that wouldn't tell you much). In some sense either
 1. Its there to be found or it isn't
 2. If it isn't... well... There it is...
 3. If its there
 1. Either we can find it with the general techniques we have now, or
 2. We need to make more assumptions, try new models and create other dedicated searches that rely more on our assumptions. Semi-infinite?
- 4. Let's do an example...
 1. General principle... at the LHC with 14 TeV of energy we should have sensitivity to larger masses. There is good reason to believe that if the squarks are about a TeV then we should have enough energy to be able to produce them directly. Strong production cross sections should make them much easier to observe whereas at the Tevatron we have gotten so sensitive to SUSY if it were there that only the things that could be allowed to exist are, in general, too heavy to be made.

Indirect Search: $B_s \rightarrow \mu\mu$

The search for $B_s \rightarrow \mu\mu$ is perhaps the most sensitive to SUSY since sparticles show up in loops

Especially sensitive at high $\tan\beta$ ($\text{Br} \propto \tan\beta^6$)

The Standard Model decay of $B_s \rightarrow \mu^+\mu^-$ is heavily suppressed

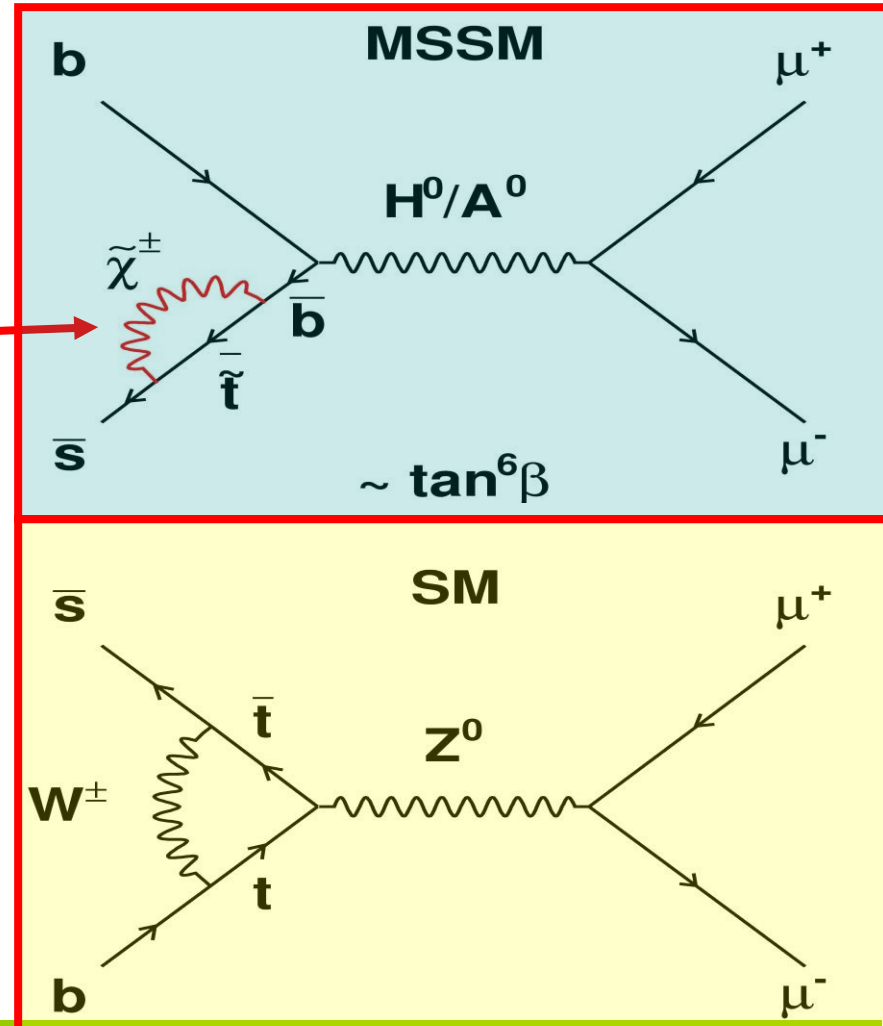

$$BR_{SM}(B_s \rightarrow \mu^+\mu^-) = (3.5 \pm 0.9) \times 10^{-9}$$

-
- How do I incorporate $B_S \rightarrow mm$?
 - How do I transition to LHC?
 - How do I do the incorporation of the other experiments to constrain which CDM model to focus on?
 - How much time do I spend on the Pheno PRL?
 - How much do I praise LHC and at the same time pat myself on the back for having stayed on Tevatron?